

WTE P11F COPY

4

Special Report 88-13

August 1988

AD-A200 444



**US Army Corps
of Engineers**

Cold Regions Research &
Engineering Laboratory

Hard-surface runways in Antarctica

Malcolm Mellor

DTIC
ELECTE
OCT 1 1 1988
S H D

Prepared for
DIVISION OF POLAR PROGRAMS
NATIONAL SCIENCE FOUNDATION

Approved for public release; distribution is unlimited.

REPORT DOCUMENTATION PAGE				Form Approved OMB No 0704-0188 Exp Date Jun 30, 1986	
1a REPORT SECURITY CLASSIFICATION Unclassified		1b RESTRICTIVE MARKINGS			
2a SECURITY CLASSIFICATION AUTHORITY		3 DISTRIBUTION / AVAILABILITY OF REPORT Approved for public release; distribution is unlimited.			
2b DECLASSIFICATION / DOWNGRADING SCHEDULE					
4 PERFORMING ORGANIZATION REPORT NUMBER(S) Special Report 88-13		5 MONITORING ORGANIZATION REPORT NUMBER(S)			
6a. NAME OF PERFORMING ORGANIZATION U.S. Army Cold Regions Research and Engineering Laboratory		6b. OFFICE SYMBOL (if applicable) CECRL	7a NAME OF MONITORING ORGANIZATION Division of Polar Programs National Science Foundation		
6c. ADDRESS (City, State, and ZIP Code) 72 Lyme Road Hanover, New Hampshire 03755-1290		7b ADDRESS (City, State, and ZIP Code) 1800 G Street, NW Washington, D.C. 20314			
8a. NAME OF FUNDING / SPONSORING ORGANIZATION	8b OFFICE SYMBOL (if applicable)	9 PROCUREMENT INSTRUMENT IDENTIFICATION NUMBER			
8c. ADDRESS (City, State, and ZIP Code)		10. SOURCE OF FUNDING NUMBERS			
		PROGRAM ELEMENT NO.	PROJECT NO.	TASK NO.	WORK UNIT ACCESSION NO.
11. TITLE (Include Security Classification) Hard-Surface Runways in Antarctica					
12. PERSONAL AUTHOR(S) Mellor, Malcolm					
13a. TYPE OF REPORT		13b TIME COVERED FROM _____ TO _____	14 DATE OF REPORT (Year, Month, Day) August 1988		15 PAGE COUNT 91
16. SUPPLEMENTARY NOTATION					
17. COSATI CODES			18. SUBJECT TERMS (Continue on reverse if necessary and identify by block number)		
FIELD	GROUP	SUB-GROUP	Aircraft	Antarctica	Runways
			Aircraft landings	Cold Regions	Snow
			Air transportation	Ice	
19 ABSTRACT (Continue on reverse if necessary and identify by block number) - The feasibility of constructing and maintaining hard-surface snow runways at McMurdo Sound and South Pole was studied. Existing technology was reviewed, and proposals for novel techniques and machines were put forward. It was concluded that all-season operation of heavy wheeled aircraft from snow runways is not a practical proposition for the short term. Other possibilities for all-season operation of wheeled aircraft were considered. These included: (a) a conventional runway of rock-fill and gravel, (b) rock-fill and gravel over permanent ice, (c) a runway on coastal glacier ice, (d) runways on bare glacier ice at inland locations. Rough cost estimates were made for each of the runway types that were considered. After examining the trends in Antarctic aviation, the following recommendations were offered: (1) develop a construction plan for a conventional runway at Marble Point, (2) proceed with site selection, equipment design, and development of ground transport for a wheel runway on the Ross Ice Shelf, (3) search for natural "blue ice" airfields at inland locations, especially locations that are not too far from the South Pole.					
20 DISTRIBUTION / AVAILABILITY OF ABSTRACT <input checked="" type="checkbox"/> UNCLASSIFIED/UNLIMITED <input type="checkbox"/> SAME AS RPT <input type="checkbox"/> DTIC USERS			21 ABSTRACT SECURITY CLASSIFICATION Unclassified		
22a NAME OF RESPONSIBLE INDIVIDUAL Malcolm Mellor			22b TELEPHONE (Include Area Code) 603-646-4100		22c OFFICE SYMBOL CECRL-EE

PREFACE

This report was prepared by Dr. Malcolm Mellor, Research Physical Scientist, Experimental Engineering Division, U.S. Army Cold Regions Research and Engineering Laboratory. The work was carried out for the Division of Polar Programs, National Science Foundation, under the 1987/88 NSF contract for Antarctic Engineering Services.

The author gratefully acknowledges the assistance of numerous individuals serving with the Polar Operations Section, Division of Polar Programs, National Science Foundation; The Public Works Office of the Naval Support Force Antarctica; the U.S. Navy Civil Engineering Laboratory; the civil engineering group of Antarctic Services, Inc. (ITT); the University of Melbourne (Australia); and the U.S. Army Cold Regions Research and Engineering Laboratory.

The contents of this report are not to be used for advertising or promotional purposes. Citation of brand names does not constitute an official endorsement or approval of the use of such commercial products.

Accession For	
NTIS GRA&I	<input checked="" type="checkbox"/>
DTIC TAB	<input type="checkbox"/>
Unannounced	<input type="checkbox"/>
Justification	
By	
Distribution/	
Availability codes	
Avail and/or	
Dist	Special
A-1	

CONTENTS

	Page
Abstract	i
Preface	ii
I. Introduction	1
II. Antarctic Air Operations	4
Flights to and from Antarctica	4
Flights within Antarctica	6
Future developments in Antarctic aviation	9
National and international considerations	9
Characteristics of standard heavy transport aircraft	10
III. Past and Present Runways at McMurdo	12
Types of runways and their locations	12
Characteristics of the sea ice and the ice shelf	12
Historical summary	14
IV. Gravel Runways and Ice Runways Near McMurdo	16
Sea-ice runways at McMurdo	16
Hard-surface runways at Marble Point	16
Runways on glacier ice near McMurdo	21
Rock fill over glacier ice	23
V. Snow Runways on the Ross Ice Shelf	24
Site conditions	24
NCEL procedure for snow processing	24
SIPRE (CRREL) procedures for snow processing	24
Soviet/Australian method for snow compaction	28
Surface paving on snow runways	28
Tentative conclusions concerning snow runways at McMurdo	29
VI. South Pole Snow Runways	30
Site conditions	30
Snow properties	30
Snow compaction to support wheel traffic	32
Sawdust additive	33
Methods for inducing intergranular bonding in dry snow	33
Inducing melt-freeze bonds by heating or wetting	34
Chemical additives	38
Formation of an ice pavement	39
Airfield landing mats and related products	40
Tentative conclusions concerning snow runways at South Pole	41
VII. Inland Runways on Blue Ice	42
Blue-ice areas	42
Development of blue ice airfields	42
Blue-ice runways to support NSF operations	42
VIII. Cost Considerations	49
General	49
Fuel costs	49

	Page
Carriage of freight within Antarctica	49
Air freight costs in Antarctica	49
Conventional construction in the United States	50
Conventional construction near McMurdo station	50
Runways on annual sea ice at McMurdo	51
Runways on glacier ice near McMurdo	51
Rock fill over ice	52
Snow runway with ice pavement at McMurdo	52
Construction at South Pole	52
Blue-ice runways at inland locations	54
 IX. Conclusions and Recommendations	 55
Conclusions	55
Recommendations	57

APPENDICES

A. Site Information for Marble Point	59
B. Impact Compaction Machines for Snow Roads and Runways	69
C. Base Course Processor for Snow Roads and Runways	75
D. High Pressure Compaction Machine	81
E. Comments on the Report <i>Compacted Snow Runways</i> by D.S. Russell- Head and W.F. Budd	87

ILLUSTRATIONS

Figure

I-1. Map of Antarctica, with station locations	2
II-1. Blue ice airfield at 80°20' S, 81°15' W	4
II-2. Ilyushin IL-76T Candid	5
II-3. Lockheed C-130E Hercules	5
II-4. Lockheed C-141B Starlifter	6
II-5. McDonnell Douglas KC-10A Extender	6
II-6. Lockheed C-5B Galaxy	7
II-7. McDonnell Douglas C-17A	7
II-8. Antonov AN-124 Condor	8
II-9. Boeing 747 SP	8
III-1. Runway locations in the vicinity of McMurdo station	13
IV-1. Sea ice thickness south of Cape Armitage	17
IV-2. Runway on first-year sea ice, McMurdo, November 1967	19
IV-3. Site plan for proposed runway at Marble Point	20
IV-4. Runway on glacier ice at McMurdo	22
V-1. NCEL Pulvimixer towed by small tractor	25
V-2. NCEL 40-ft snow plane	25
V-3. SIPRE rotary snow plow adapted for runway processing	26
V-4. Heavy roller proposed by Australian engineers	27
VI-1. Uniaxial compressive strength of snow as a function of time during the sintering period	30
VI-2. Variation of the strength of dry snow with the bulk density	31
VI-3. Uniaxial compressive strength of natural South Pole snow plotted against bulk density	31
VI-4. Penetration resistance as a function of depth in South Pole snow	31

Figure	Page
VI-5. Penetration of dyed water into dry snow at DYE-3, Greenland, 1975	35
VI-6. Polyethylene honeycomb used to stabilize loose soil	40
VII-1. Blue ice airfield at Rosser Ridge, Pensacola Mountains	43
VII-2. Location of blue-ice runway at Rosser Ridge	44
VII-3. Location of blue-ice runway at Mount Lechner	45
VII-4. Location of blue-ice runway at Patriot Hills	46
VII-5. Surface features in the vicinity of Mount Howe and d'Angelo Bluff	48

TABLES

Table	Page
II-1. Characteristics of some transport aircraft	11
IX-1. Subjective summary of conclusions concerning runway concepts considered in this study	56

Hard-Surface Runways in Antarctica

MALCOLM MELLOR

I. INTRODUCTION

In September 1987, NSF asked USACRREL to study the prospects for all-season operation of wheeled aircraft in Antarctica, with emphasis on runways for McMurdo station and South Pole station.

Preliminary studies, from mid-September to mid-November 1987, concentrated on concepts for the construction of snow runways at McMurdo and the South Pole. A need for special construction equipment was envisaged, and concept designs for three novel machines were produced (Appendices B, C, D). A systematic review of past research on snow runways was felt to be necessary, and a dormant CRREL project to produce a *monograph on snow roads and runways* was revived. A draft of this monograph, by G. Abele, should be available soon. A library search of relevant literature failed to turn up much detail on Soviet techniques for making snow runways in Antarctica, but a report on comparable work done in Antarctica by Australian engineers was commissioned in November 1987 and delivered in March 1988 ("Compacted Snow Runways," by D.S. Russell-Head and W.F. Budd). Site inspections at McMurdo and the South Pole were made in November 1987, a trip report was prepared in December 1987, and a preliminary report was submitted to NSF in January 1988. Further studies were carried out at CRREL, and this report was completed in April 1988.

The heavy transports that have been proposed for all-season flights to, and within, Antarctica include the C-141 and the KC-10A, neither of which is particularly well-suited for soft field operation because of high tire pressures. To build all-season snow runways for these aircraft, new technology has to be developed. The necessary R&D program is likely to be expensive, with no guarantee that the final outcome will be acceptable in logistic and economic terms (largely because of the need for repeated renewal of the pavement as snow accu-

mulates). There is also a safety concern if the strength of a snow pavement is not well above the required minimum strength.

Given the difficulty of making all-season snow runways for heavy wheeled aircraft, alternatives have to receive serious consideration.

The existing system, which depends on the ski-wheel LC-130 for inland operations and for summertime* flights to and from New Zealand, is expensive. The LC-130 is a 34-year-old design, the replacement cost is very high, payload is reduced by ski takeoffs in summer, and payload is small for intercontinental flights and cross-continent flights. In 28 years of operation there have been three total losses of LC-130 aircraft and several recoveries and rebuilds after crashes.

Sea-ice runways at McMurdo are excellent for wheel operations in springtime. They cannot be relied upon for summer and autumn operations over the long term, even with major improvements in construction and maintenance procedures, since the general ice sheet breaks out, either annually or at less predictable longer intervals, depending on the location.

The only other possibility for an all-season wheel runway near McMurdo station is construction on the hard glacier ice of the Ross Ice Shelf, near the eastern limit of the ablation zone. There was a runway on bare glacier ice in this area from 1966/67 to 1970/71. A new runway at this site could be built either by planing the bare ice surface or by compacting a thin snow cover over the hard ice. If efficient procedures for summer maintenance could be developed, the runway would be semi-permanent, since the ice shelf moves very slowly in this area. The major objec-

*In this report, reference to the seasons means southern hemisphere seasons. The winter solstice is in June; the summer solstice is in December.

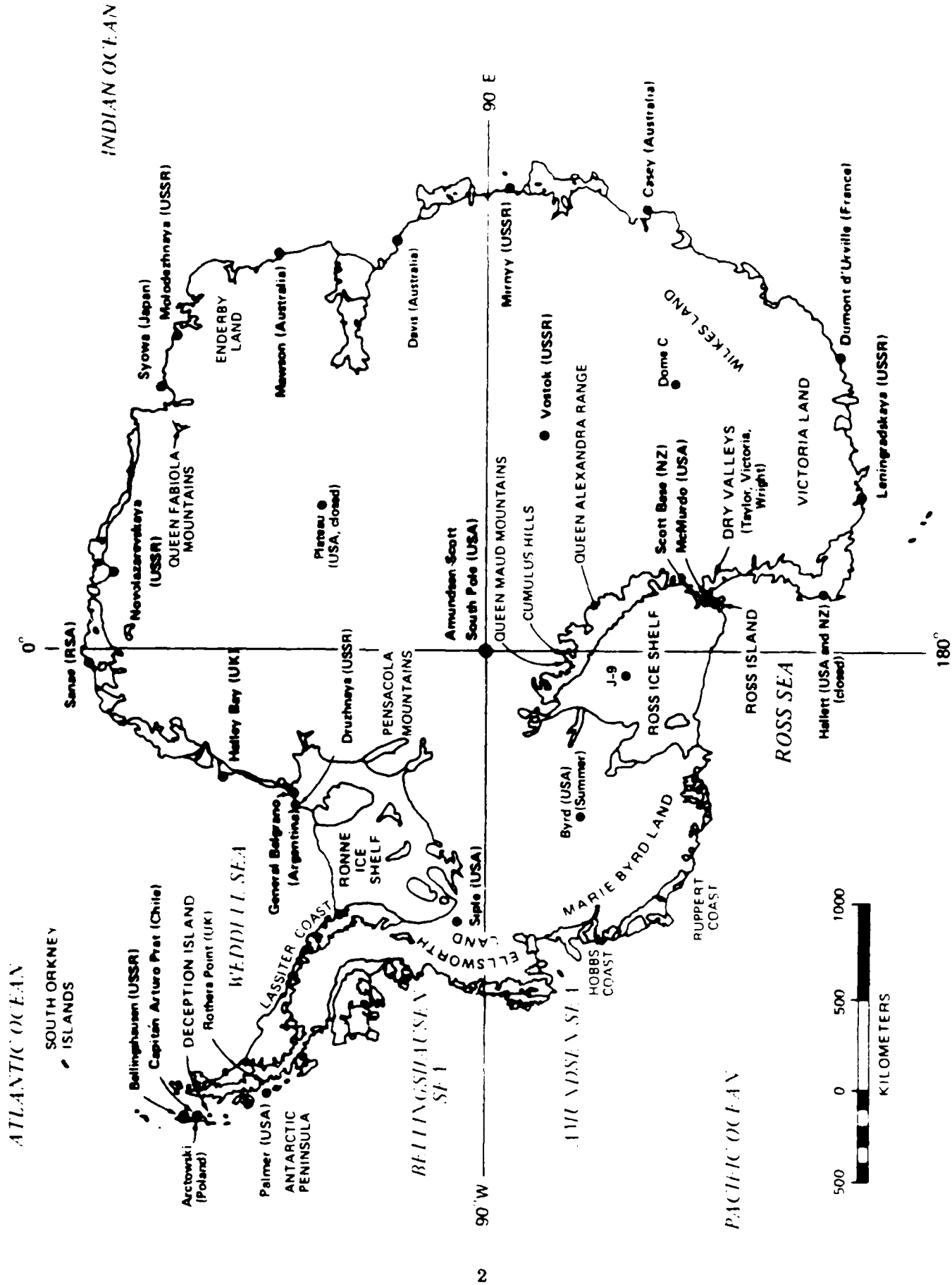

Figure I-1. Map of Antarctica, with station locations.

tion to this type of runway is the distance from McMurdo station—about 9 miles across the winter sea ice and about 15 miles via Pram Point and the ice shelf in summer. This objection is itself an indication that ground transport needs attention.

A more stable runway could be built at the same ice shelf site by placing gravel over the glacier ice to form a semi-permanent surface. The initial cost for this type of runway would be much greater than for an ice runway at the same site. The objection to the distance between the airport and McMurdo station would still apply.

Marble Point is an ice-free area about 50 miles from McMurdo station, at the other side of the sound. Over the long term, construction of a conventional permanent airport at Marble Point seems inevitable. Several studies and site investigations have been made over the past 32 years, and an environmental impact statement has been prepared. The documents reveal no major technical problems, and they are in broad agreement on the design for a runway. In the light of arctic construction experience for recent decades, some details of the construction proposal may seem overly conservative. However, the project would undoubtedly be expensive and it would necessitate relocation of some major logistic services. A start to construction work at Marble Point, even on a very modest scale, seems an unbeatable investment for the future.

If heavy wheeled aircraft are to land and take off at the South Pole, a runway must be built on snow and it must be surfaced with material derived from snow (highly compressed snow, snow-ice, or ice). The use of manufactured materials for

the runway surface seems impractical because of high freight costs, insufficient air-freight capacity, and the need for periodic replacement. As mentioned earlier, a technical capability for building high-strength snow runways has not yet been developed, even for favorable sites near the coast. At the South Pole, very low temperatures, even in mid summer, are a serious handicap in snow runway construction. Conversely, the low temperatures are an asset once a snow runway is in operation.

As an alternative to an expensive and risky R&D investment in snow runway technology for the South Pole, it might be possible to establish a low-cost satellite airfield for heavy wheeled aircraft within 300 miles of the Pole. A commercial enterprise recently established a wheel runway in a natural blue-ice area 580 nautical miles from the Pole, and it seems possible that there are blue-ice areas suitable for low-cost runways in the region around Mt. Howe and d'Angelo Bluff. An airfield in this region could accommodate direct flights from New Zealand and South America, as well as flights from McMurdo. It could serve as transshipment center for sled trains and short-haul flights to Pole and other inland stations or camps. Given the very low cost of blue-ice runways and the potential for prior exploitation of suitable sites by others, a survey of blue-ice runway sites ought to be undertaken soon, following procedures that were developed for NSF by USA-CRREL in 1974 (when two airfield sites in the Pensacola Mountains were located and surveyed).

II. ANTARCTIC AIR OPERATIONS

Flights to and from Antarctica

For many years the United States was the only country that had the capability of flying passengers and freight to and from the main land mass of Antarctica. This capability was based initially on the use of sea-ice runways at McMurdo, with guaranteed service limited to the period from October to mid-December. The potential for all-season capability developed when the ski-wheel LC-130 came into service in 1960/61, and the first winter flight was made in June 1967. The U.S. capability has remained essentially the same for almost 30 years; wheeled aircraft can fly to and from McMurdo from late winter to early summer, while long-range ski-wheel aircraft can (with some reservations) operate year-round. Ski-wheel aircraft can, in principle, fly between South America and the snowfields close to Palmer at almost any time of the year.

U.S. air operations have made McMurdo and Pole much more accessible than the Antarctic stations of most other countries, but the flight schedule is still strongly seasonal. The last flights of summer depart McMurdo for New Zealand at the end of February, leaving the station without planned air service for several months. Air drops are made at McMurdo and Pole in June, using USAF aircraft that fly round trips from New Zea-

land without landing in Antarctica. The winter fly-in of personnel and cargo takes place in August; several flights are made from Christchurch to McMurdo by USN ski-wheel LC-130 aircraft. These flights deliver the maintenance crews who prepare the runways for the main aviation season, which begins in early October. Deliveries of cargo and passengers by wheeled aircraft are made from early October until early December, when the sea-ice runway is in service. C-141 aircraft of the USAF operate until mid-November, and a standard C-130 of the RNZAF operates until the sea-ice runway closes in mid-December. Thereafter, all flights to and from New Zealand have to be made by LC-130 ski-wheel aircraft operating from the snow skiway on the ice shelf. The season closes at the end of February.

All flights which land at the South Pole or other inland stations are made by ski-wheel LC-130 aircraft. Flights to Pole start at the beginning of November, with a heavy schedule of fuel and cargo flights during the first three weeks of November. The capacity for inland flight operations is limited over most of the summer, since the LC-130 aircraft also have to carry passengers to and from New Zealand. The last flight to Pole is usually made in mid-February.

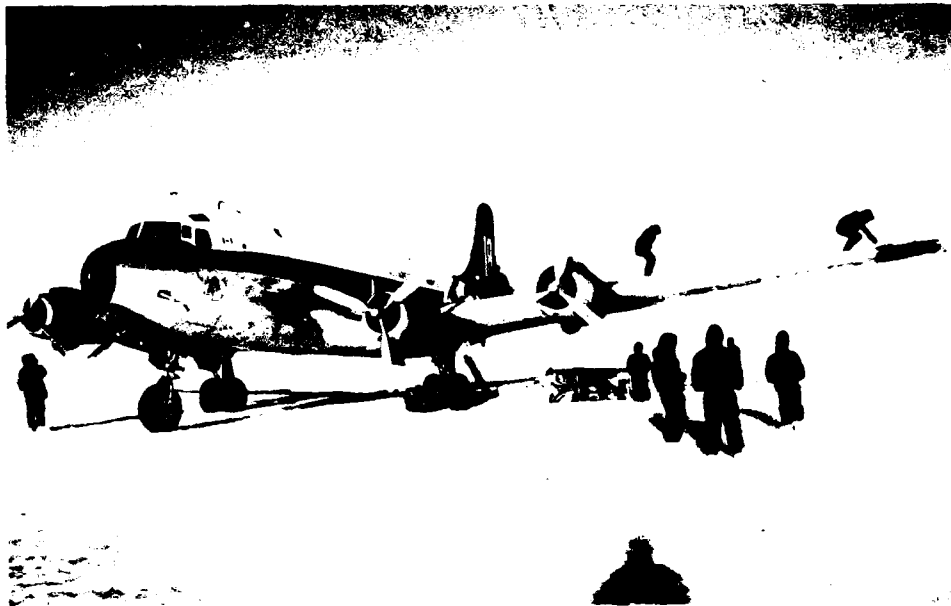

Figure II-1. Blue ice airfield at 80°20' S, 81°15' W. (Photo by C.W.M. Swithinbank.)

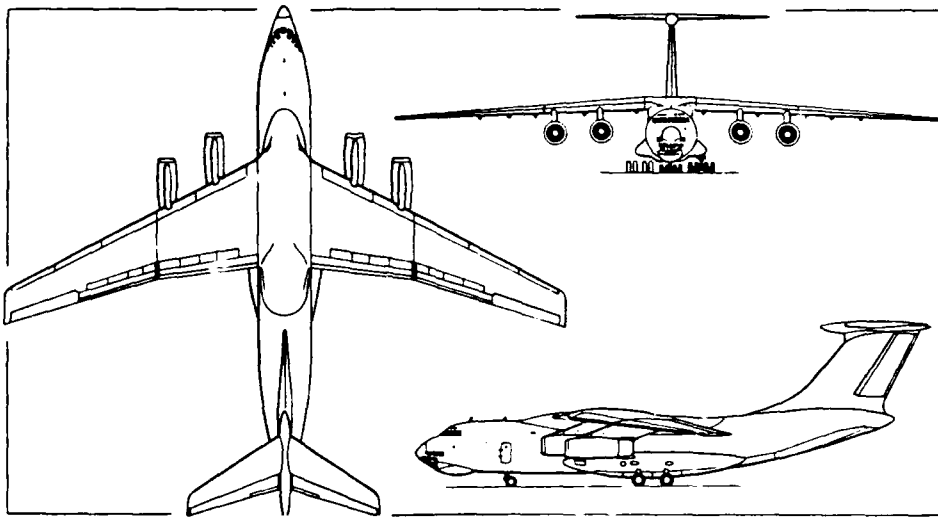

Figure II-2. Ilyushin IL-76T Candid (*Jane's/Pilot Press*).

Other countries now have capabilities for flying passengers and freight to and from Antarctica. For several years the Soviet Union has been flying wheeled aircraft between Maputo, Mozambique, and Molodezhnaya on the mainland of East Antarctica. The compacted snow airstrip near Molodezhnaya* is maintained year-round by frequent rolling, but it is closed to heavy wheeled aircraft during December, January and the first days of February because of softening in the summer warmth. A second airfield on compacted snow has been constructed at Novolazarevskaya, which serves as an alternate for Molodezhnaya during

*Actually 6 miles east, near Mt. Vechernyaya.

the operating season. The principal aircraft used for the service was originally the Ilyushin IL-18D, but in recent years the flights have been made with the Ilyushin IL-76D and the heavier Ilyushin IL-76T (the latter has a max. gross 16% greater than the C-141).

Argentina has a gravel runway at Marambio station on the Antarctica Peninsula, so that relatively short flights can be made to and from Ushuaia, Argentina. Chile has a gravel airstrip at Marsh station on King George Island in the South Shetlands, and relatively short flights to and from Punta Arenas, Chile, are possible. France is currently constructing a hard surface runway at Dumont d'Urville (which is less than 1,500 nautical miles from Hobart, Tasmania).

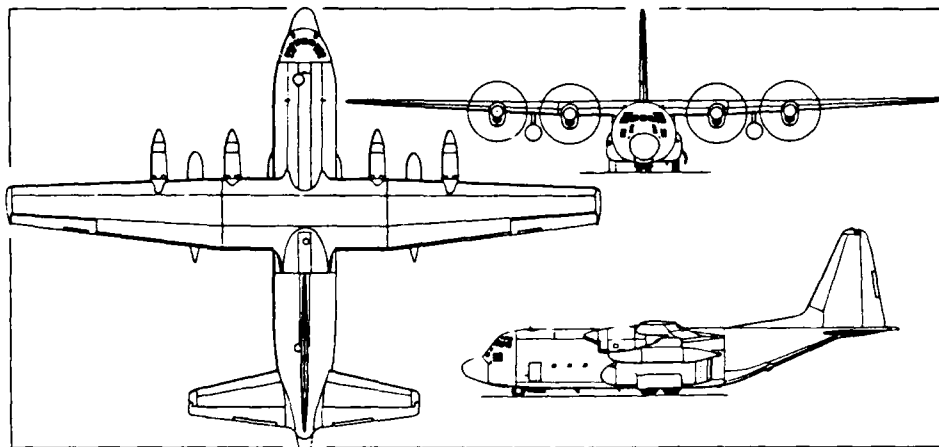

Figure II-3. Lockheed C-130E Hercules (*Jane's/Pilot Press*).

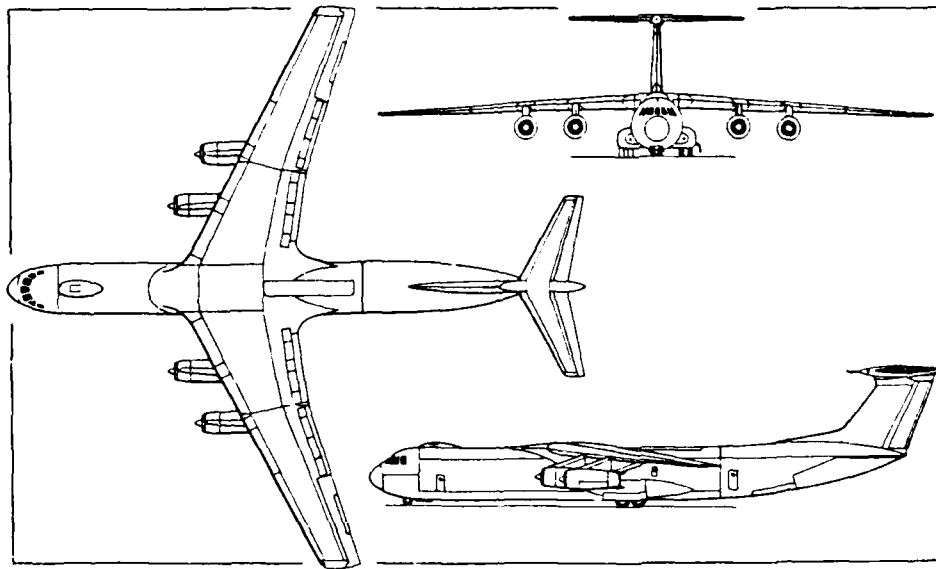

Figure II-4. Lockheed C-141B Starlifter (Jane's/Pilot Press).

A blue-ice airfield in the Patriot Hills (Ellsworth Mountains) is now being used for private charter flights from Punta Arenas, using wheeled aircraft (Fig. II-1). Privately chartered ski-wheel Twin Otters recently carried a non-government Japanese group from South America to Syowa, with refueling stops at various coastal stations.

Antarctica is easily within range of flights originating in New Zealand, Australia, Southern Africa, and South America. Tourist round-trip

flights have been made, without landing, from Australia and New Zealand.

Flights within Antarctica

U.S. operations within Antarctica have always depended mainly on ski-wheel aircraft for all but local flights. Starting with R4D and P2V aircraft during the IGY, the Antarctic fleet was upgraded to LC-130 aircraft in 1960 (USAF) and 1961 (USN). Smaller ski-wheel aircraft have been used, notably the single-engine DHC-3 Otter and

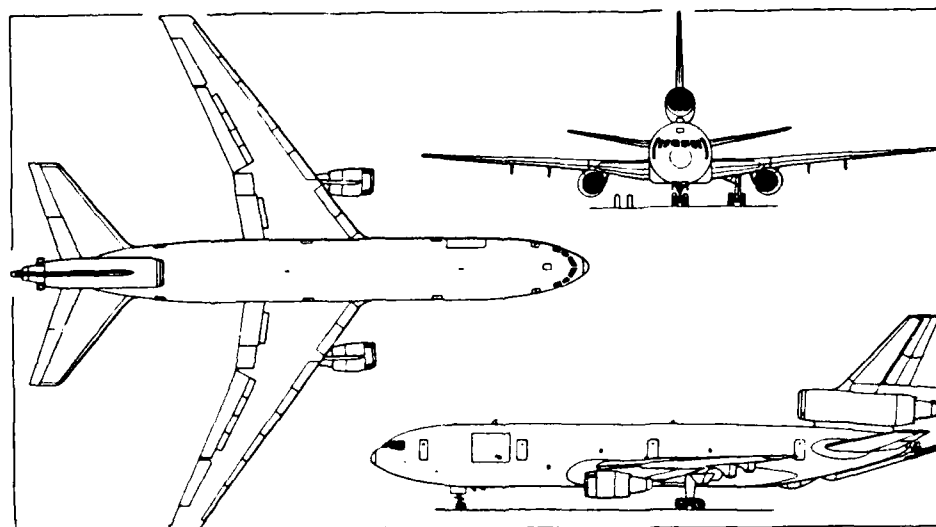

Figure II-5. McDonnell Douglas KC-10A Extender (Jane's/Pilot Press).

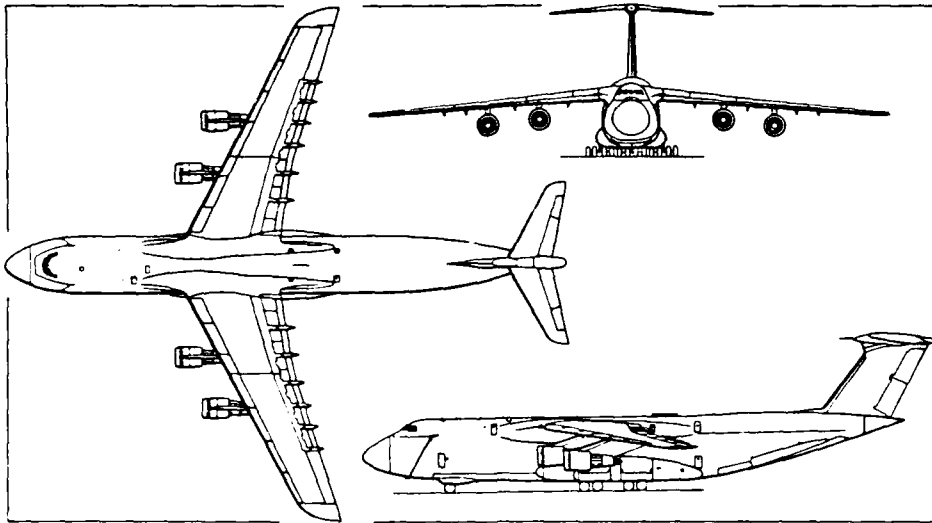

Figure II-6. Lockheed C-5B Galaxy (Jane's/Pilot Press)

the DHC-6 Twin Otter. Helicopters are used mainly for relatively short flights from McMurdo.

Before 1970, heavy wheeled aircraft sometimes flew long inland missions that did not call for landings. The C-124 made air-drops at the South Pole and the C-121 was used for research missions. These flights were made from the sea-ice runway at McMurdo. The standing orders for emergency procedures called for gear-up landing on the Ross Ice Shelf in the event of bad weather developing at the McMurdo runway during the

course of a flight. No consideration was given to using blue-ice areas as emergency alternates, although on one occasion, in 1958, four C-124 wheeled aircraft arriving from New Zealand used a glacier-ice emergency runway at Cape Hallett when the weather closed in at McMurdo.

Other nations have used ski and ski-wheel aircraft for inland flights, but on nothing like the scale of U.S. operations. The ski-wheel Twin Otter has been popular. A Dornier 128-6 and a Dornier 228-100 were fitted with ski wheels. The

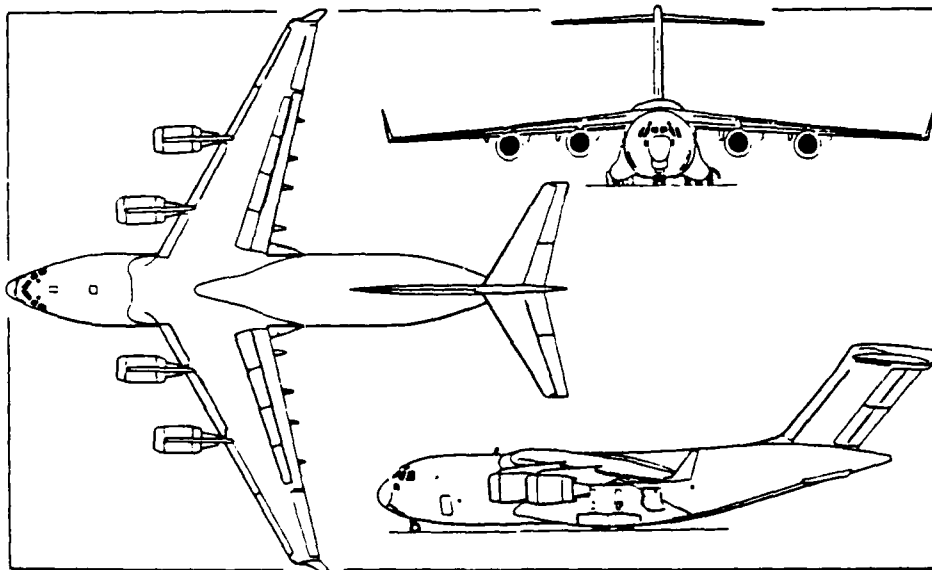

Figure II-7. McDonnell Douglas C-17A (Jane's/Pilot Press).

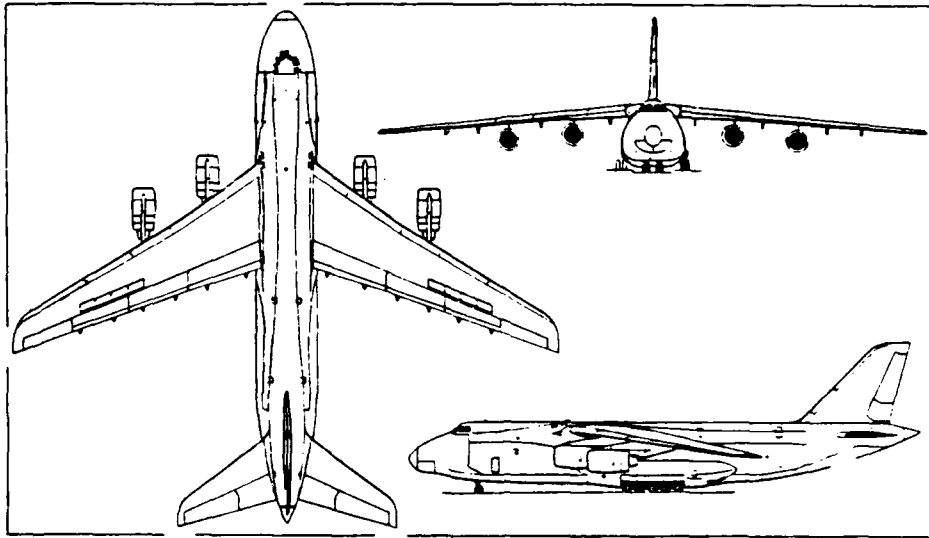

Figure II-8. Antonov AN-124 Condor (Jane's/Pilot Press).

main fixed-wing aircraft used by the Soviet Union has been the Ilyushin IL-14 (MI-8 helicopters carry cargo over shorter distances).

Ski aircraft can often land on unprepared snow surfaces, but some areas are unsuitable because of large sastrugi or because of crevasses. Several U.S. aircraft have been damaged or destroyed by the effects of rough sastrugi, especially when employing JATO. Areas of high sastrugi may be of considerable extent, but the roughest patches are usually interspersed with relatively smooth ar-

reas, which can be found by low-level air reconnaissance in clear weather, or by ground parties. At inland stations the hazards of snowdrifts and sastrugi are mitigated by grooming the snow with simple equipment, thus making a ski runway.

The ski-wheel C-130 has been the magic carpet of Antarctic aviation. The standard C-130A first flew in 1954 and deliveries began at the end of 1956, i.e. right at the beginning of the modern era of Antarctic activity. A test version of the ski-wheel modification first flew in 1957; tests were

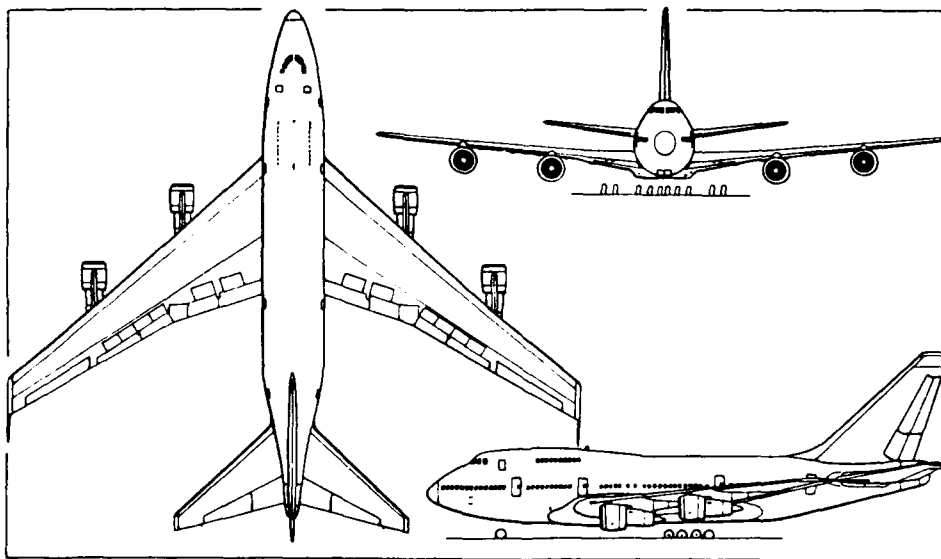

Figure II-9. Boeing 747 SP (Jane's/Pilot Press).

completed in 1958. Twelve C-130A aircraft were modified for the USAF, receiving the designation C-130D, and they were in service in Greenland by 1959. Four C-130B aircraft were converted for Antarctic use by the USN and delivered in 1960. The interim designation was C-130BL, the final designation LC-130F. Three of these still survive (one recovered from a crash site in 1987/88). Later, about 1975, six C-130H aircraft were converted for the USN and NSF, receiving the designation LC-130R. Four of these still survive. The most recent conversion by Lockheed was four LC-130H aircraft for the USAF.

The Teflon-surfaced aluminum skis of the LC-130 can be moved up or down relative to the wheels when the landing gear is extended. The main skis are 20 ft long and 5.5 ft wide, while the nose ski is 10 ft long and 5.5 ft wide. The complete ski installation weighs 2.8 tons. In soft snow, when the full area of the skis is bearing, the nominal contact pressure is about 4 lbf/in.² at the maximum takeoff weight for the aircraft. On very hard snow, where there is no sinkage and only the keel is bearing, the nominal contact pressure is about 9 lbf/in.²

Conventional heavy transport aircraft with wheels have tire pressures that are very much higher than the contact pressures for skis. The transport aircraft with the lowest known tire pressures, the Ilyushin IL-76, has inflation pressures that are almost 10 times the pressures of C-130 skis (37-73 lbf/in.²). The standard C-130 has a normal inflation pressure of about 96 lbf/in.². The C-141 has 180 lbf/in.², and the under-wing wheels of the KC-10A have 200 lbf/in.². Thus, in order to use conventional wheeled aircraft for flights within Antarctica, hard-surface runways are needed. The practical possibilities are: (1) conventional paved runways or gravel runways on soil, rock, or slow-moving ice, (2) runways on hard snow-free ice, (3) compacted snow runways with snow-ice surfacing. Of these, (1) is considered too expensive for current U.S. operations, and available sites are few and far between.

Runways on snow-free ice seem attractive, both as bases for inland operations and as port-of-entry airfields. The concept has been proved by the airfield in the Patriot Hills that was developed by a Canadian/ British private group (and is likely to be used by the Chilean Air Force). There are probably dozens of blue-ice sites suitable for use by large wheeled aircraft, both in remote inland areas and in coastal regions.

So far, runways on compacted snow have only

been made in coastal areas, where high summer temperatures facilitate the compaction process (but also weaken the finished runway in mid-summer). At cold inland locations, the snow is very dry and lacking in cohesion; it is difficult to compact by simple application of pressure, and the time-dependent sintering process which forms intergranular bonds is extremely slow. Soviet engineers are said to be experimenting with compacted snow runways at Vostok, and part of this report deals with proposed techniques for making processed snow runways at the South Pole.

Future developments in Antarctic aviation

Until now, Antarctic aviation has had an expeditionary character, with aircraft selected and modified to suit the environment and with expedient airstrips improvised to meet minimum requirements. Short-term logistic considerations and short-term financial concerns have prevailed.

In the future, it seems inevitable that Antarctic aviation will evolve away from bush flying and towards conventional aviation. In other words, there will be greater use of standard wheeled aircraft, there will be more permanent airfields, non-government civil aviation will establish a presence, and a more complex route structure will develop, both within Antarctica and for inter-continental flights. The economics of air operations will change, and there will be more realistic cost accounting.

The dominance of the U.S. in Antarctic aviation depends largely on the ski-wheel C-130, which exists only in limited numbers. NSF currently owns seven LC-130 aircraft, and the New York Air National Guard has four new ski-wheel C-130 aircraft. The old USAF ski-wheel C-130's have been retired to dead storage at Davis-Monthan AFB. As far as is known, there are no ski-wheel Hercules outside the U.S. In the future, U.S. dominance in Antarctic aviation is likely to decline in relative terms.

National and international considerations

Northern hemisphere countries need southern hemisphere bases for flights to and from Antarctica. The most suitable land masses are New Zealand, Australia (Tasmania), Southern Africa, and South America. Subantarctic and southerly islands could also be useful, for example Kerguelen

(France) or the Falklands (U.K.). The need to fly into Antarctica via a foreign country makes international cooperation essential. It also creates a certain vulnerability to changes in international relations. The development of multiple air routes to and from Antarctica should be beneficial in the long run.

Flights within Antarctica are not restricted by national territorial claims under the present treaty arrangements. However, there are *de facto* national controls over the various airstrips in Antarctica. The country which has built, maintained and operated an airfield can effectively exclude, or impede, aircraft of other nationalities. As air operations by treaty-nations and newcomer nations increase, pressure on the few sites suitable for permanent airfields will increase. Some nations (or private groups) may decide to preempt exclusionary occupation of these sites by making landings, recording the facts, and leaving evidence of prior use at the sites (e.g. refuge huts).

Characteristics of standard heavy transport aircraft

Conventional airport runways designed for unrestricted use by all types of aircraft have to be both very strong, to support heavy transports, and very smooth, to permit small wheels to roll easily at high speeds. By contrast, expedient runways in remote areas may be quite rough, relatively weak, or both. The aircraft that use these expedient runways have to be matched to the limitations of the runways. In other words, there may be limits on the aircraft weight, the stall speed, the takeoff run and, perhaps most important, the characteristics of the landing gear.

In Antarctica, there are few runways that match those of major airports. In the interior, there are no real runways, and only a few places where wheeled aircraft can land. Until now, the solution has been to adapt the aircraft for ski-wheel operation so that unprepared surfaces or very simple snow runways can be used.

The current effort to provide all-season wheel runways for the C-141 represents a radical upgrade rather than an incremental improvement. If a runway can handle a C-141, it can handle practically any kind of aircraft (given sufficient length), since the C-141 is a heavy aircraft which normally operates with high tire pressures.

While it is obviously desirable to have high quality runways that can handle any type of aircraft, it should be recognized that high quality is likely to mean high cost. If all-season runways have to be built and maintained with limited bud-

gets and limited logistics, then it may be necessary to accept lower standards and to restrict their use to aircraft that have soft-field and rough-field capabilities.

Standard versions of the C-141 and KC-10A have tire pressures that are 20 to 50 times higher than the bearing pressure of an LC-130 ski, and even the skis of an LC-130 can produce some sinkage on the McMurdo ski-way in mid-summer. The C-141 and the KC10A seem far from ideal for soft field operations, and the proposal to operate them from snow runways has to be questioned. The Ilyushin IL-76, which is closely comparable to the C-141, looks a much better bet for expedient snow runways, since it can reduce the inflation pressure of its 16 main wheels to only 20% of the inflation pressure for the eight main wheels of the C-141. However, the IL-76 is not likely to be available to NSF.

The largest of the U.S. transports, the C-5B Galaxy, has more favorable tire pressures than the C-141, with normal inflation of about 111 lb/in.² in its 24 main wheels (137 lb/in.² in the four nose wheels). Presumably these pressures could be reduced with the aircraft operated at reduced weight. The C-130 has normal inflation pressures of about 96 lb/in.², and it is understood that some reduction can be tolerated with the aircraft below maximum gross weight.

A ski-wheel modification for the C-141 has been proposed and rejected from time to time, but it is not known whether modification of the wheel landing gear has been considered, for this or other aircraft. In the civil sector, the DC-10 was given an extra four wheels for cargo service by fitting an extra mainwheel unit under the fuselage (as on the KC-10A). On some aircraft, "big wheel, fat tire" modification might be feasible.

A new heavy-lift transport, the C-17A, is being built for the USAF by McDonnell Douglas, but it will not be operational until the nineteen-nineties. The first version of the aircraft will probably not be very suitable for soft field operation, but it may be possible to influence the design consideration for future modifications.

A more innovative small transport aircraft is currently under development by Beech Aircraft for the Defense Advanced Research Projects Agency (DARPA). This is the Rutan-designed AT³, a twin-engine STOL aircraft with two sets of high aspect ratio wings in tandem. One version of the design has greater range than the C-130, comparable speed, considerably smaller payload, and low takeoff and landing speeds. Maximum payload for the aircraft is 6 ton.

Table II-1
Characteristics of some transport aircraft.

C-130 (Lockheed Hercules) (not LC-130)

Max T-O weight	78 ton
Max payload	≈ 22 ton
Full-load range	2160 nm
Cruise speed	up to 325 knot
Nominal full-load T-O roll	≈ 3600 ft
Nominal landing distance	1700 ft
MLG	4 wheels, 60 in. dia., 96 lbf/in. ²

Ilyushin IL-18 (Military variant IL-20 "Coot")

Max T-O weight	71 ton (D-model-long range)
Max payload	≈ 15 ton
Full-load range	≈ 2000 nm
Cruise speed	up to 364 knot
Nominal full-load T-O roll	≈ 4300 ft
Nominal landing distance	2800 ft
MLG	8 wheels, 36.5 in. dia., 114 lbf/in. ²

C-141 (Lockheed Starlifter)

Max T-O weight	≈ 160 ton
Max payload	35 ton
Full-load range	≈ 2500 nm
Cruise speed	up to 490 knot
Nominal full-load T-O roll (sea level)	4300 ft
Nominal landing distance	2800 ft
MLG	8 wheels, 44 in. dia., typically about 180 lbf/in. ²

Ilyushin IL-76 (NATO reporting name "Candid")

Max T-O weight	≈ 187 ton (T-model)
Max payload	44 ton
Full-load range	2700 nm
Cruise speed	up to 430 knot
Nominal full-load T-O roll (sea level)	2800 ft
Nominal landing distance	1500 ft
MLG	16 wheels, 51 in. dia. 36-73 lbf/in. ² (adjustable in flight)

C-5B (Lockheed Galaxy)

Max T-O weight	418 ton
Max payload	187 ton
Full-load range	2882 nm
Cruise speed	up to 490 knot
Nominal full-load T-O roll	8300 ft

Nominal landing distance	2380 ft
MLG	24 wheels, 49 in. dia., 111 lbf/in. ²

KC-10A - cargo version (USAF modification of McDonnell Douglas DC-10, series 30CF)

Max T-O weight	295 ton
Max payload	≈ 85 ton
Full-load range	3797 nm
Cruise speed	up to 490 knot
Nominal full-load T-O roll	10,400 ft
Nominal landing distance	6130 ft
MLG	12 wheels (3x tandem dual wheels, one group on centerline), 52 in. dia., 200 lbf/in. ² for underwing units, 155 lbf/in. ² for centerline unit.

C-17A (McDonnell Douglas—first flight scheduled for 1990)

Max T-O weight	285 ton
Max payload	86 ton
Full-load range	2400 nm
Cruise speed	350 knot at low altitude 0.77 Mach at high altitude
Nominal full-load T-O roll	7600 ft
Nominal landing distance	2700 ft
MLG	12 wheels (2x tandem dual wheels with tandem legs), 50 in. dia.; 138 lbf/in. ²

Antonov An-124 (NATO reporting name "Condor")

Max T-O weight	447 ton
Max payload	165 ton
Full-load range	2430 nm
Cruise speed	up to 467 knot
Nominal full-load T-O roll	≈ 9800 ft
Nominal landing distance	2625 ft
MLG	20 wheels, 50 in. dia.

Boeing 747 SP

Max T-O weight	315 to 350 ton
Max payload	>100 ton
Full-load range	5150-5850 nm
Cruise speed	up to 592 knot
Nominal full-load T-O roll	8000 ft
Nominal landing distance	5300 ft
MLG	16 wheels, 46 in. dia., 183 lbf/in. ²

III. PAST AND PRESENT RUNWAYS AT MCMURDO

Types of runways and their locations

Fixed-wing aircraft have operated from ice runways and snow skiways at McMurdo for more than 33 years. All aspects of fixed-wing operations have been based on ice or snow, including maintenance, parking, storage, fueling and living facilities for the airfield workers.

Four distinct types of runways have been built:

- (1) Wheel runways on thick bay ice (multi-year sea ice).
- (2) Wheel runways on annual sea ice (first-year sea ice).
- (3) Wheel runways on hard glacier ice.
- (4) Ski runways (skiways) on perennial snow (accumulation area on the ice shelf).

The general locations for these four types of runways were as follows:

Type(1) – on multi-year sea ice in the bay directly south or southwest of Observation Hill, with shelf ice to the east and to the south. Main runway orientation typically 7/25.

Type(2) – on first-year sea ice, south, or west, or northwest of Hut Point. Main runways south of Hut Point typically 7/25; main runways west of Hut Point Peninsula typically 16/34.

Type(3) – on snow-free glacier ice in the ablation zone of the ice shelf, south-southwest of Observation Hill. Main runway orientations approximately 17/35 and 16/34.

Type(4) – on permanent snow in the accumulation zone of the ice shelf, southeast of Observation Hill. Main runway 7/25, crosswind runway 2/20.

The exact locations of the sea-ice runways and the skiways have changed from time to time (Fig. III-1); periodic breakout of the multi-year ice, calving of the ice shelf, and excessive growth of plowed snow berms have influenced changes of location.

References to past locations are sometimes confused because the name Williams Field has been applied to different types of runways and different locations. The first location to be called Williams Field was a Type(1) runway, which was destroyed by a breakout in 1962. The second Williams Field was also Type (1); its life was terminated by ice breakout in 1965. In 1965/66 the

name Williams Field was transferred to the snow skiways on the ice shelf; the ice shelf skiways are still called Williams Field. From 1966 to 1971, the name Outer Williams Field was given to the runways built on glacier ice between Hut Point and Black Island. Use of the name Williams Field, which should probably be applied to the complete air facility, will be avoided in this report.

Additional confusion has arisen because some people have failed to distinguish between the ice shelf and the old multi-year sea ice that abuts the shelf.

To understand why the McMurdo airfield has occupied so many different sites, it is necessary to look at the glaciology of the area.

Characteristics of the sea ice and the ice shelf

McMurdo Station lies at the tip of a rocky peninsula that juts out from Ross Island. To the south and east of this peninsula lies the Ross Ice Shelf, which forms a small bay immediately south of Cape Armitage and Pram Point. Sea ice forms in this bay, where it is sheltered and well anchored against breakout. In this area, some of the sea ice can remain in place for several years, thus becoming very thick (≈ 10 m) *multi-year ice* that has relatively low salinity. The sea ice in McMurdo Sound is not very stable, and it breaks out every summer, bringing open water all the way to Hut Point, or further. When this open water freezes in winter, it forms *annual ice*, or *first-year ice*; near McMurdo station, the annual ice reaches a thickness of about 8 ft (2.5 m) by the end of November.

The *ice shelf* is the most stable body of ice. It is technically a glacier, in that it is formed and nourished by snowfall. The area between White Island and Ross Island is an area of net accumulation, in which annual snow accumulation exceeds annual ablation. It is thus a permanent snowfield. In the local area southeast of Observation Hill, the shelf is about 100 to 150 ft (30–45 m) thick, becoming thicker with increasing distance from the ice front. The permeable snow-ice is invaded by seawater, which forms a sort of water-table, or brine horizon. In this area, the shelf moves seaward at a rate of approximately 100 m/yr. The ice front calves (break off to form icebergs) periodically. The end result of ice flow and calving is that the ice front advances steadily for a period

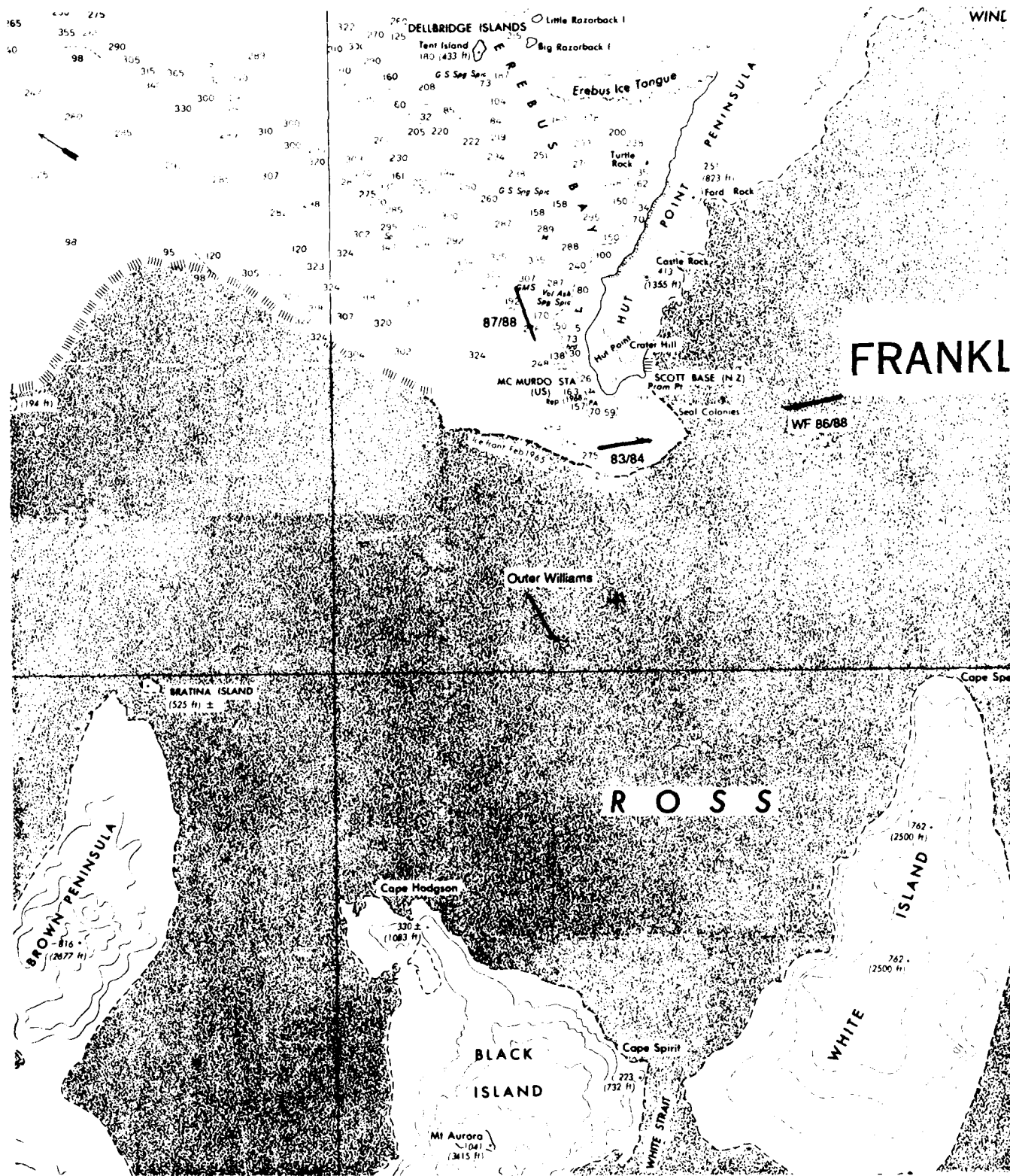

Figure III-1. Runway locations in the vicinity of McMurdo station.

of years, then retreats abruptly. Anything built on the ice shelf is eventually carried out to sea by this process. Further to the west, in the area north of Black Island and Brown Peninsula, net ablation prevails. Annual ablation exceeds annual snow accumulation and the surface is bare ice in summer. This is ice that formed further upstream, in the region south of Black Island and White Island, and it progressively wastes away as it flows to the sea. Due north of Black Island, the flow rate is only about 30 m/yr; further west, between Black Island and Brown Peninsula, the flow is only about 2 m/yr. Wind seems to be a major factor in determining which areas have net accumulation and which have net ablation. In the ablation areas downwind of Black Island and Mt. Discovery, wind-blown rock dust accelerates the summer ablation by darkening the ice surface, and it produces irregular patches of intense melting. Surface melt streams flow in summer, creating hummocks and gullies.

The least stable ice in the area is *annual sea ice*. The annual ice usually starts to form in late March as the open water freezes. The new ice can be broken by storm action up to late June. The ice thickness increases throughout the winter and spring, reaching a maximum in early December. By mid-December the ice sheet has warmed up to the melting point, and thereafter it thins rapidly by bottom-melting. By mid-January it has lost about half its thickness and becomes very weak. In the local area, it usually breaks out by wave action in early February, drifting north into the open water of the sound under wind action. Ice-breaker operations can influence the ice break-out. Some small areas near Cape Armitage are particularly susceptible to rapid decay in early summer, and thus are dangerous. During the growth period, salinity is highest at the top and bottom of the sheet, with about 10‰ (parts per thousand) salinity in the surface layer. Salinity is lower in the mid-section, say about 5‰. The surface of annual sea ice in the local area is usually very smooth (unless there has been disturbance by a storm in early winter). It acquires a snow cover during winter and spring.

In some places and during some periods, the sea ice remains in place for two or more years, thus becoming *multi-year ice* (sometimes called bay ice). During its first summer, much of the brine drains out of the warm ice under gravity, leaving the residual salinity low. In the following winter this ice becomes thicker by growth at the

bottom, it accumulates more snow on the surface, and it is stronger than first-year ice. Eventually, old sea ice can become about 10 m thick. Having survived the summer and become very thick, multi-year ice is more resistant to breakout in subsequent summers. However, it cannot last indefinitely, as it is being pushed seaward by the ice shelf. This thrust against the land can also form pressure rolls in the sea ice, thus making its surface uneven. Preferential ablation of the snow cover also causes unevenness.

These things explain why it has never been possible to have a single all-season airfield in the same location. The accumulation area of the ice shelf can only be used for ski aircraft, and even the skiways have to be relocated from time to time in order to compensate for ice flow and calving. The ablation area of the ice shelf can provide semi-permanent all-season runways for wheeled aircraft, but it is thought to be too far from the station, and there have been maintenance problems. The multi-year sea ice has been used, but there are maintenance problems, the ice breaks out periodically, and the surface deteriorates in mid-summer. The annual sea ice provides good temporary runways, but these runways last for only a few months, and they are not usable beyond late (or mid-) December.

Historical summary

The following notes give a chronology of airfield projects and air operations at McMurdo.

- 1954/56 Site survey for IGY airfield.
- 1955/56 First sea-ice airfield built about 2.5 nautical miles southwest of the station (just about on a line joining Hut Point and Mt. Erebus). Ice 14–30 ft thick, snow cover 12–30 in. Snow bulldozed away to form runway. One runway approx. 7/25, the other approx. 10/19. Length approx. 6,000 ft and 4,000 ft (accommodating R4D, R5D, P2V).
- 1956/58 Airfield upgraded for C-124 and C-121 and new 6,000 ft skiway added alongside. Patching method for melting runways developed in January 1957. First flight to South Pole, October 31, 1956. Also in October, first fatal crash at MCM (C-121), plus serious damage to a C-124. Fatal crash of C-124 near Hallett in November 1958. 1700-ft gravel runway built at Marble Point in 1957.

- 1960 USAF took first ski-wheel C-130 aircraft (A-model) to Antarctica, flying cargo to Byrd and Pole.
- 1960/61 Introduction of Navy LC-130 aircraft for inland flights. Skiway parallel to sea-ice runway early in season. Operations moved to skiway on the ice shelf later in season.
- 1961/62 Snow berms alongside runway 20 ft high. Berms extended 150-200 ft to each side of the runway. Ice under the berms depressed, with cracks alongside. Operations moved to a skiway on the ice shelf in early February 1962, shortly before the ice broke up and went to sea.
- 1962/63 New runway built on multi-year sea ice in October 1962. Location about 3 nautical miles SSW of Cape Armitage. Snow cover 4-5 ft, pressure rolls up to 2 ft high. Snow plowed and bulldozed to sides, undulations chipped down by modified Pulvimixers, low spots flooded with seawater. Skiway on the ice shelf in heavy use for summer operations with ski-wheel aircraft.
- 1964/65 Snow berms alongside the new runways 30 ft high. Ice under the berms was depressed, with major cracks. In February 1965, ice breakout encroached onto the crosswind runway, forcing a move to the ice shelf. This was the end of the second sea-ice airfield. Heavy calving from the ice shelf in February 1964 and February 1965.
- 1965/66 A new 10,000 ft runway on first-year sea ice was built about 2 miles due south of Pram Point. New skiways were built on the ice shelf about 3 miles southeast of Pram Point. The sea-ice runway was directly in line with the main skiway (7/25, 10,000 ft long). RNZAF 40 Squadron began operating between CHC and MCM. Minor calving from ice shelf.
- 1966/67 Runways were built on hard glacier ice in the ablation area of the ice shelf, approximately 7 nautical miles SSW of Cape Armitage. A rotary ice chipper was used to plane the surface flat. Main runway approximately 16/34 in 1967. Heavy summer ablation formed deep melt pools, necessitating application of protective snow cover. MAC began operation of wheeled C-141 aircraft, necessitating lengthening of runways and enlargement of parking apron. New buildings provided for ice shelf facility. Minor calving from ice shelf.
- 1967/68 Glacier-ice runway re-aligned to approximately 17/35. Sea-ice runway 1.5 nautical miles due south of Pram Point. Minor calving from ice shelf. First WINFLY in June 1967.
- 1970/71 Glacier-ice airfield closed at end of season (heavy maintenance effort and long travel distance). Last piston-engine fixed-wing aircraft (C-121) phased out. Minor calving from ice shelf early in 1970. C-121 crashed in October 1970.
- 1971/72 Sea-ice runway (7/25) 2 miles due south of Pram Point. Skiways on the ice shelf 3 miles southeast of Pram Point (to runway intersection). Sea-ice runway in line with main ski runway.
- 1974/75 Edge of ice shelf within 50 yd of approach end of main ski runway.
- 1975/76 Skiways moved 1,000 ft away from edge of ice shelf.
- 1976/77 Skiways moved another 5,000 ft and ice shelf camp re-opened at new location, 4.5 miles from main station.
- 1979/80 Major calving from ice shelf early in 1980.
- 1983/84 Sea-ice runway in same general location, 2 nautical miles due south of Cape Armitage and Pram Point.
- 1986/88 Ice shelf skiways located 6.5 nautical miles ESE of station.
- 1987/88 Sea-ice runway on annual ice located 2.5 nautical miles NW of station (ice in usual location had not gone out for 3 years and surface was too rough).

IV. GRAVEL RUNWAYS AND ICE RUNWAYS NEAR MCMURDO

Sea-ice runways at McMurdo

Runways on first-year sea ice are relatively easy to prepare at McMurdo, provided that operations are limited to the period when the ice is thick, with temperature below its melting point (September–December). The winter snow cover is plowed off, leaving a perfectly flat surface that is very smooth. Ideally, a thin snow cover should be retained in order to reflect solar radiation and to provide reasonably good braking and steering. Dark stains and debris on the ice should definitely be avoided.

In the areas that are used for runways on first-year ice, the thickness is typically 8 ft or more by October. Thickness increases slightly up to mid-December, after which time there is both rapid thinning and significant softening of the ice as it warms up. During the period October to mid-December, the ice is thick enough and strong enough to support a fully-loaded C-141 for long periods. After mid-December the ice retains enough bearing capacity to support a C-130 for another month or so, but it is not stable for a very large permanent load, such as is imposed by a closely-spaced group of fuel bladders, or by large snow berms.

A runway on first-year sea ice can be thickened artificially by direct surface flooding or by spraying water into the air and letting the resulting "wet snow" fall back. The water used for these surface treatments is much more saline than the interior of the natural ice sheet (35‰ against 5‰), and concentrated brine residues have to be removed if the surface is not to become slushy as the weather warms up. An artificially thickened runway could retain adequate bearing capacity through the summer, but it would eventually suffer the fate of the general ice sheet. Surface melting in December/January would be a problem.

Access to a sea-ice runway is by one or more roads plowed across the sea ice. Transition between the land and the sea ice becomes a problem by mid-November. Ice deformation and flooding in the tide crack zone create deep pools, and surface melting of the ice is accelerated by solar radiation absorbed on relatively dark ice surfaces, especially where mud and gravel are transferred to the ice by vehicle traffic.

Multi-year sea ice can, with great difficulty, be made to provide all-season operation for the C-130 and smaller aircraft. In January, surface de-

terioration by melting is serious, and the runway pavement has to be maintained by regular dusting with snow, by de-watering operations, and by pothole patching. Planing by a rotary ice chipper may be needed. After the summer season, surface smoothing is required. Possibilities are snow compaction (before temperatures drop too much), ice chipping (at any time), and surface flooding (after winter conditions return).

In principle, the skiway on the ice shelf is not needed if a runway on multi-year ice or on artificially-thickened ice is maintained through the summer season. In reality, there is no assurance that the sea ice will remain in place, so that the skiway has to be retained in case the sea ice breaks out.

Sea-ice runways have been the mainstay of McMurdo air operations for more than 30 years, and they will continue to be used in the near future. Under current arrangements, the sea-ice runway has to be supplemented by the ice shelf skiway in order to maintain air operations throughout the year. It is estimated that the average annual cost of a sea-ice runway plus the skiway is at least \$1 million. Given the importance of flights into and out of McMurdo, this is an acceptable expense, even though it produces no long term assets. The expense that is of more concern stems from the enforced reliance on very expensive ski aircraft for all summer operations and for any winter flights that may be required.

Hard-surface runways at Marble Point

So far, there are only two permanent gravel runways for transport aircraft in Antarctica. One is at Marambio on the Antarctic Peninsula (Argentina) and the other is at Marsh on King George Island (Chile). A third is under construction at Dumont d'Urville on the Adélie Coast (France).

Marble Point was identified as a potential airfield site in 1956/57, and a short (1700 ft) runway was built there in 1957. A special Seabee unit was formed in 1957 to carry out detailed surveys and site investigations. This work was carried out in 1957/58 and 1958/59, and reports were produced for each season's work. At the same time, a contract was let to Metcalf and Eddy, a Boston engineering firm. Metcalf and Eddy worked with the

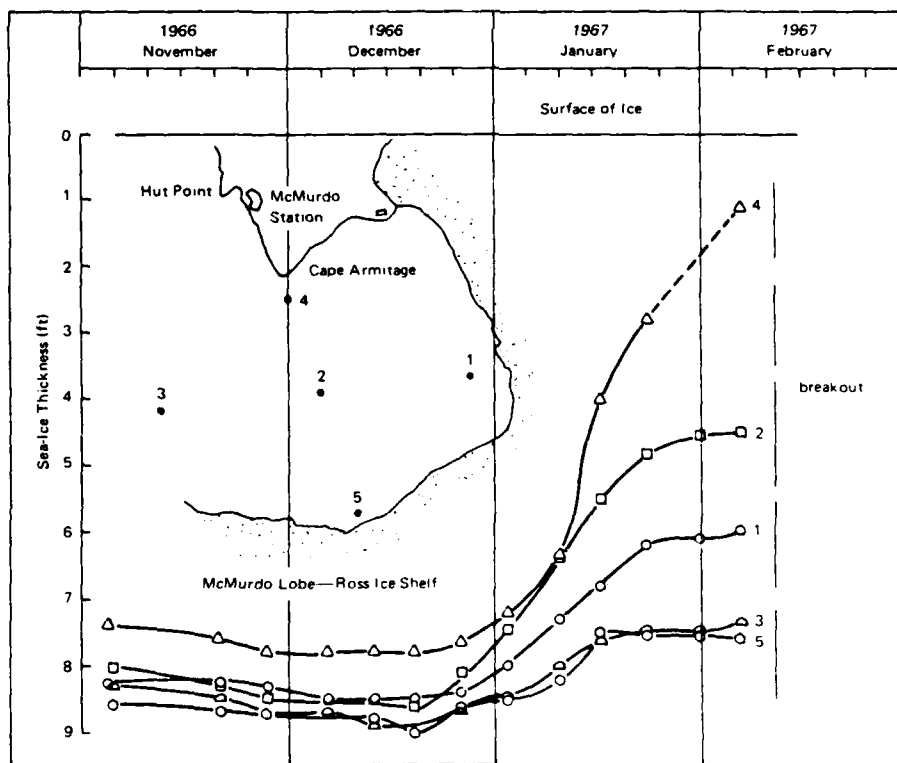
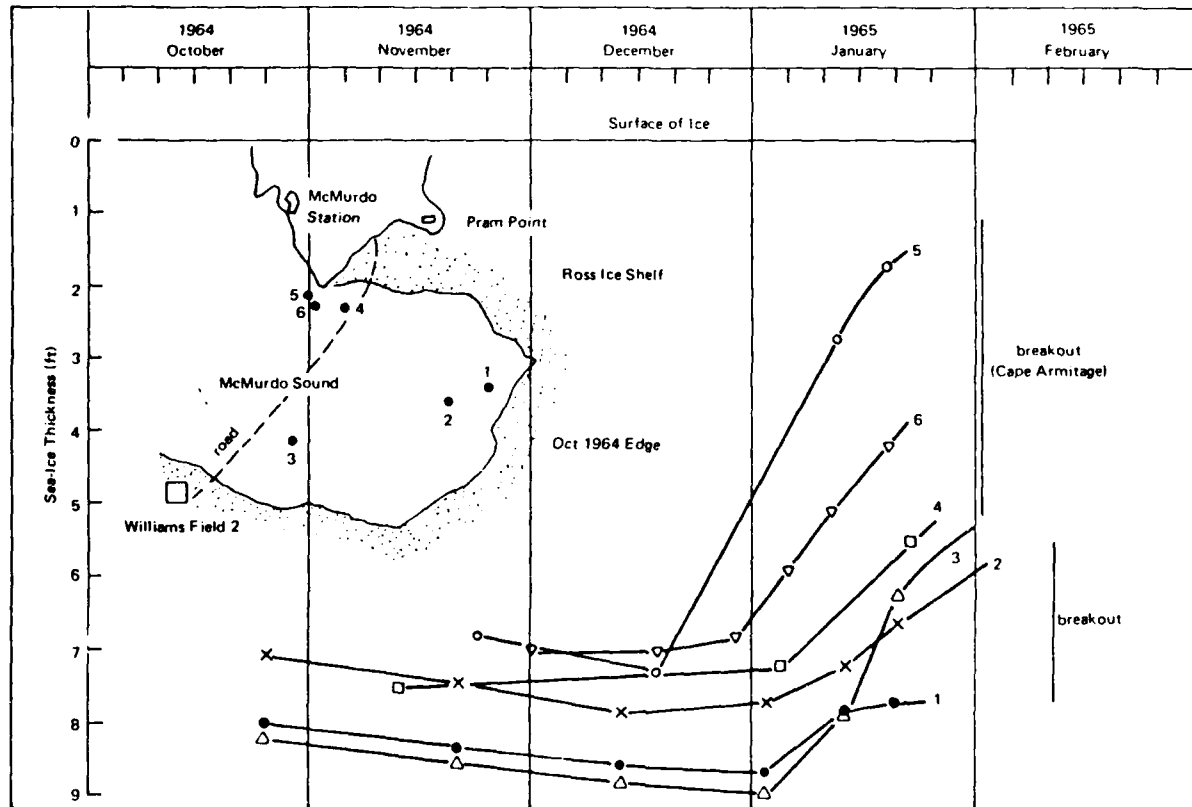

Figure IV-1. Sea ice thickness south of Cape Armitage (from "Engineering Manual for McMurdo station," 1979).

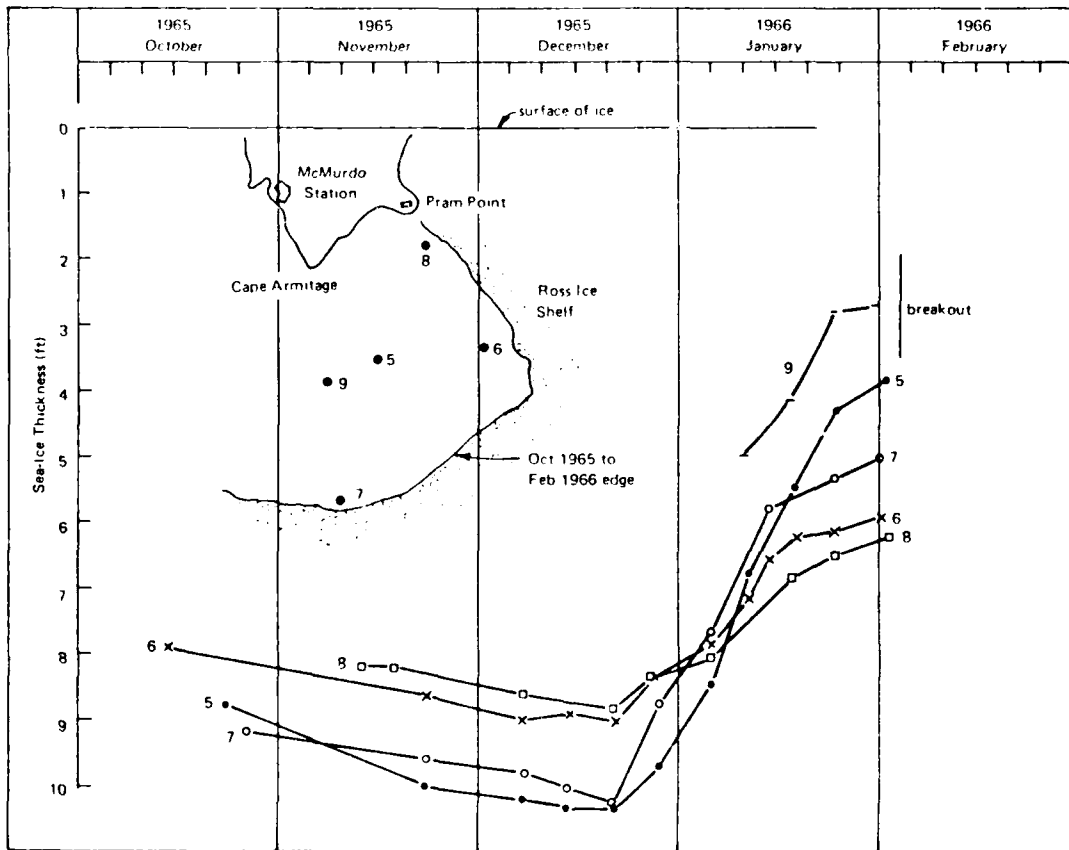
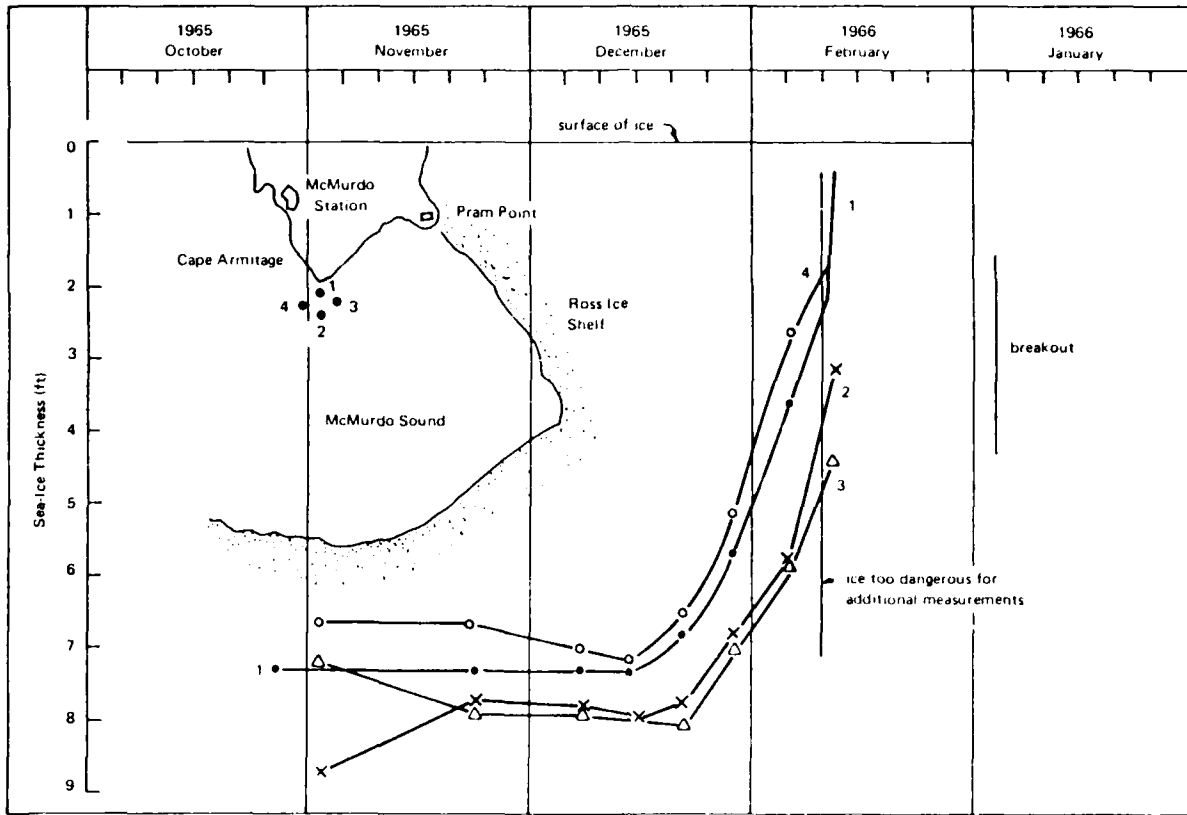
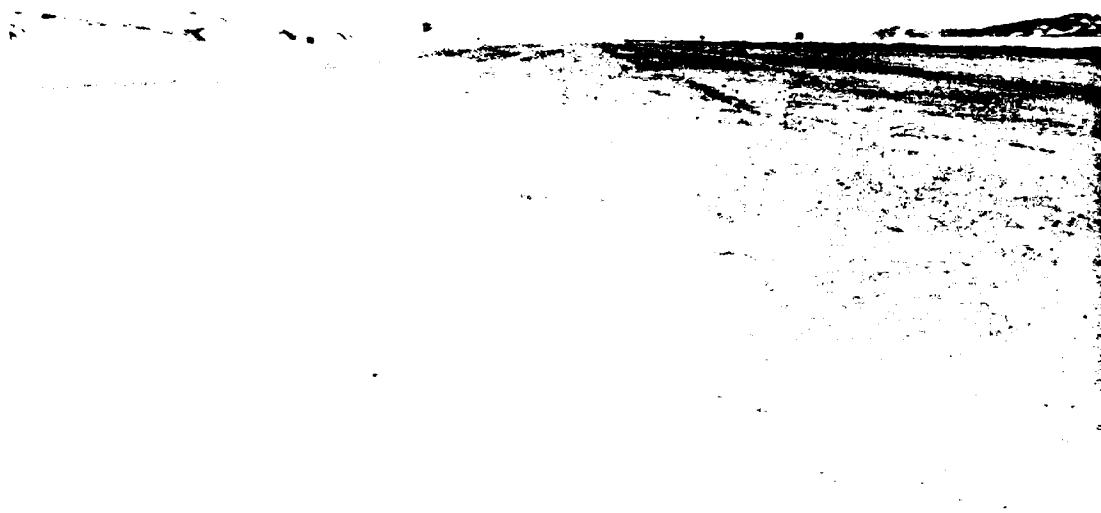
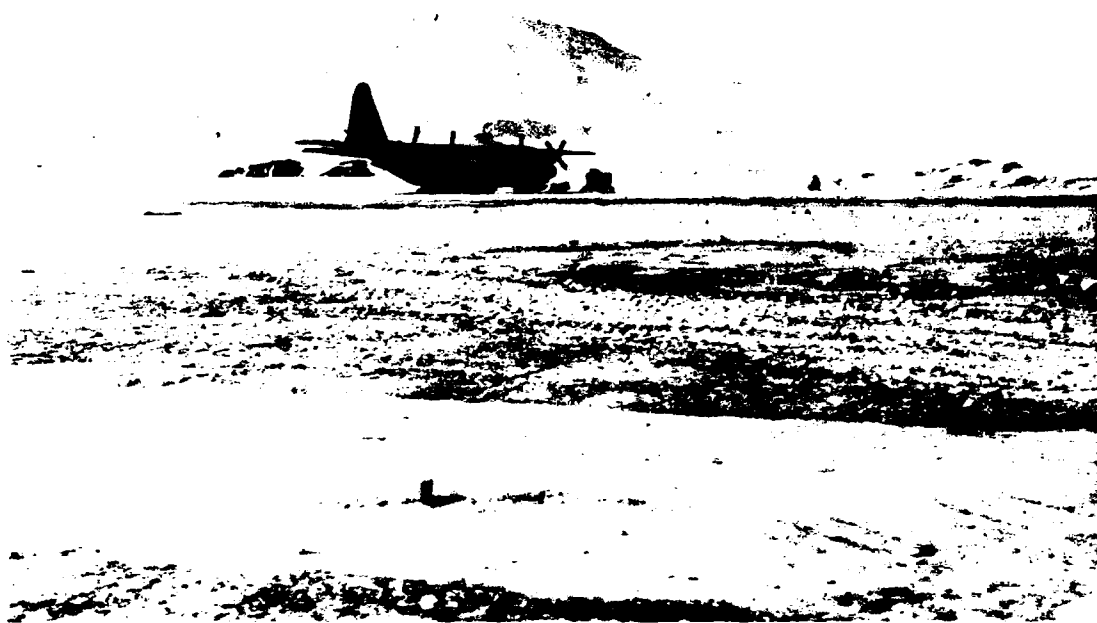

Figure IV-1 (cont'd). Sea ice thickness south of Cape Armitage (from "Engineering Manual for McMurdo station," 1979).



a. Looking down the runway towards White Island.



b. Looking across the parking apron towards Mt. Erebus.

Figure IV-2. Runway on first-year sea ice, McMurdo, November 1987.

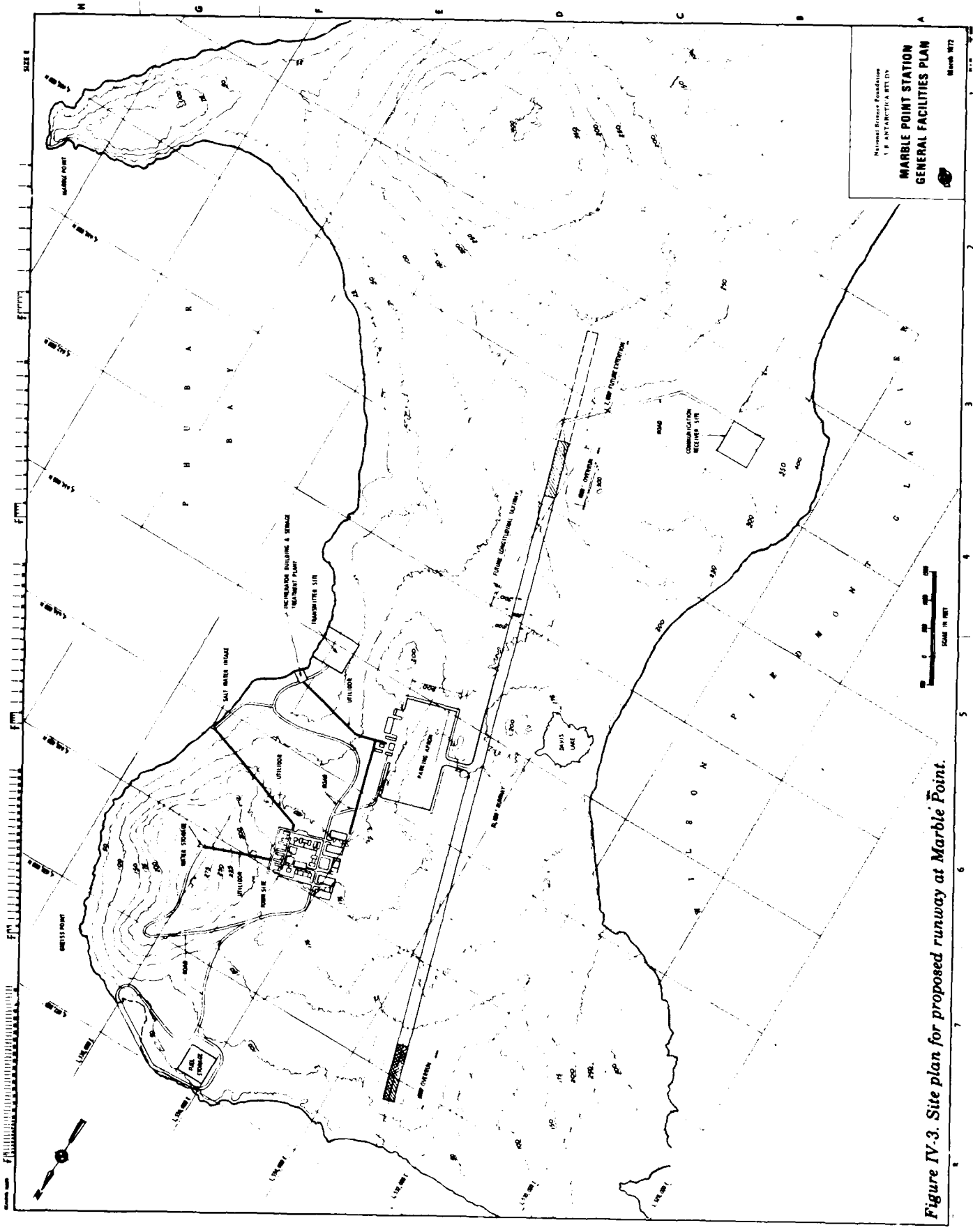

Figure IV-3. Site plan for proposed runway at Marble Point.

Seabee unit on site investigation and also used the field data to make a feasibility study on airport construction. Two reports were submitted by Metcalf and Eddy. A report covering Marble Point was also issued by the Bureau of Yards and Docks in 1962.

With minor qualifications, it was concluded that construction of an airfield and associated facilities is feasible at Marble Point. Estimates were made for runway lengths of 5000, 8000 and 10,000 ft. Cost estimates were high, and no action was taken to commence construction.

Proposals for an airfield were revised in 1971, and a study was carried out for NSF by Bechtel Incorporated. Reports were submitted in March 1972. Taking the site data from the earlier field investigations, designs were modified and revised estimates were made. There was a comparison of projected costs for construction and operation by military and civilian groups. Some of the facilities proposed in the previous studies were trimmed in the interest of economy. For example, taxiways were eliminated because there is unlikely to be enough traffic to justify taxiways. It is hard to extract a simple indication of cost from the detailed analyses of the Bechtel report, but it appears that the construction cost for the airport and associated facilities was around \$200 million (1972 dollars). Again, no action was taken.

As part of a planning study in 1978, Holmes and Narver re-examined the Marble Point proposals and made new estimates for the construction of a station, an airfield, and a port facility. The idea of using ice fill for the runway, mooted in the earlier study, was favored.

A draft environmental impact statement for construction at Marble Point was drawn up in 1979, and it was updated in 1984/85 as a joint effort by NSF and PACDIV of NAVFACENGCOM.

Marble Point studies have been discouraging, primarily because they seem to imply construction, at great expense, of a completely new station to replace McMurdo station. It would now be interesting to have estimates for an expedient airstrip at Marble Point, assuming minimal fill depth, no surface paving, and primitive facilities comparable to those at the ice strip and Williams Field. However, if a project is actually undertaken, it probably makes more sense to do the job properly, complete with surface stabilization to subdue dust and loose gravel.

Even if no early action is contemplated for Marble Point, it would be useful to make a low-budget review of previous studies, and to develop

a simple construction plan for the runway only. In the 30 years since the first Marble Point study was made, a great deal of experience in Arctic construction has accumulated and, in some cases, designs have become more realistic and economical.

Appendix A reproduces part of the 1985 environmental impact statement. It describes the environment at the proposed construction site, and gives some details of the proposals for airfield construction.

Runways on glacier ice near McMurdo

The only feasible area for glacier-ice runways near McMurdo station is the eastern limit of the ablation area, somewhere close to a line running from Cape Armitage to the peak of Black Island. To the east of this line there is net accumulation of snow. To the west of the line the ice becomes dirtier and the summer ablation more intense, so that surface relief is too rough for runway construction. The old Outer Williams Field was slightly west of the line, near the limit for net ablation.

To prepare a runway on bare glacier ice, the first step is to choose a smooth area with the required size, orientation and surface gradients, taking into account any obstructions on the approaches. The ice is then graded to get rid of bumps and waves. The ice is too hard for effective grading by a conventional blade. In principle, a conventional grader blade can be fitted with sharp cutting teeth, but with this arrangement the single-pass cutting depth of the teeth has to be restricted and the vehicle requires very good traction. A better arrangement is to use a powered milling drum on a grading vehicle. In the past, Pulvimixers and other rotary-drum machines were modified for ice chipping, but it is probably better to design a machine for the specific purpose. The necessary theory and practical experience already exist.

After grading, the runway is ready for use, but different types of maintenance are needed at different times of year. In winter, snow has to be removed, probably by conventional plowing. In summer, melting is the problem, especially non-uniform melting and puddling on the surface.* A key element of summer maintenance is preserva-

*Note that it may be possible to develop meltwater reservoirs on this part of the shelf, thus creating a bulk supply of fresh water.

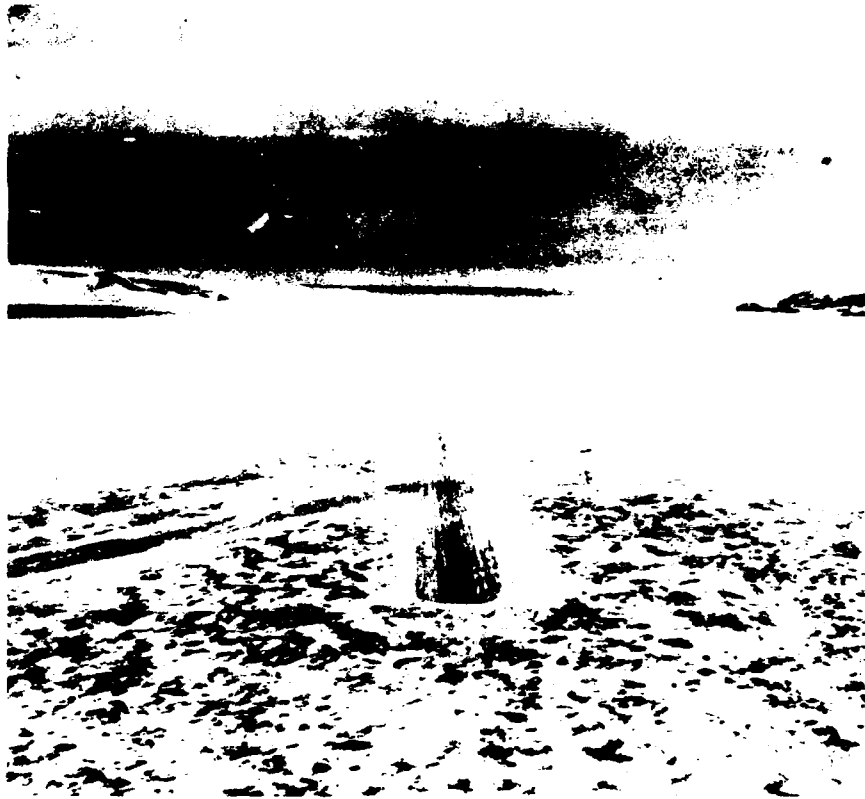

U S Navy photo (XAM-80148-10-67) by Jackie W Richards

Figure IV-4. Runway on glacier ice at McMurdo (the old Outer Williams Field).

tion of a whitish reflecting surface to minimize the absorption of solar radiation. This can be brought about either by gentle scarifying of the ice surface, by dusting with snow blown from the sides by rotary snow plows or, in suitable circumstances, by snowmaking equipment. It may also be worth considering power brooms and vacuum cleaners for mopping up wetness. If melt patches or puddles form, they have to be dealt with promptly by removing excess water and packing the depressions with wet snow (pothole patching).

As an alternative to planing a bare ice surface, it would be possible to select a site that is just inside the area of net accumulation, and then compact the thin and patchy snow against the hard ice beneath. In this situation, wetting and re-freezing of the snow layer might be more practical than it would be on a deep, dry snowfield. The main benefit of snow-over-ice construction would be higher resistance to surface melting in mid-summer.

Another possibility is to prepare two parallel runways: "17 Left" and "17 Right." "17 Right" would be near the limit of *winter* snow cover to permit October operation with a minimum of snow plowing effort. "17 Left" would be slightly further east, near the limit of *summer* snow cover. "17 Left" would be unused, and would retain its snow cover, until ablation problems developed on "17 Right" at the end of December.

At the time of year when the sea ice south of Cape Armitage is safe for travel (winter-spring), the glacier site is about 8 nautical miles from McMurdo station. In summer, when travel is via Pram Point and the ice shelf, the distance is 50% more. With vehicles of the Delta type, journeys of this length are manageable. However, air-cushion vehicles would be more suitable, as direct travel would be feasible.

A summer runway on glacier ice was maintained for four years, from 1966/67 to 1970/71, so the technical feasibility is not in question. The drawback was heavy summer maintenance and

long travel distance. For a re-examination of glacier-ice runways, the emphasis should be on summer maintenance and ground transport.

Rock fill over glacier ice

Active moraines on glaciers provide a natural example of rock fill over ice. Some types of rock glaciers illustrate the great longevity of a thick rock fill over ice. Both natural and artificial rock fills on ice can be found around McMurdo station. Originally, the natural shoreline on the north side of Winter Quarters Bay had a thick layer of scree overlying old ice. The gravel on the ice wharf and adjacent sea ice is an artificial cover. Part of the "beach road" near the sewer outfall appears to be rock fill over sea ice (partly from cleanup of the old dump).

Gravel roads were built on glacier ice in Greenland by the U.S. Army during the period 1958-1964. The location, near Thule AB, was the ablation area at the edge of the ice cap. The primary purpose of the roads was to provide a transition for trucks delivering supplies from Thule to the loading area for oversnow sled trains leaving for the interior. A spur road provided access to an ice tunnel and under-ice camp. Glacier ice in this area moves only very slowly, and there are no significant crevasses. However, summer ablation is very severe, and major melt streams form. The net loss of ice by ablation is about 8 ft/yr, so that the roads soon become elevated above their surroundings. The thaw index for the area, based on air temperatures, is in the range 480 to 640 Fahrenheit degree-days (270 to 360 Celsius degree-days). The mean annual temperature of the ice at the site (as given by deep ice temperatures) was about -11°C .

The depth of fill selected for the Greenland projects was 3 ft, with 2.5 ft of coarse material and 6 in. of finer gravel on the surface. Fills up to 5.5 ft were tested, but the additional thickness had no advantage over the 3 ft fill. The second of the two "ramp roads" was 6,400 ft long, with a 50 ft travel lane and 25 ft wide protective berms on each side. It had a total of 134,000 yd³ of fill, with an average

haul distance of 4 miles. The job took two months, with 33,000 man-hours and 19,000 machine-hours. The project used, on average, four shovels, six cranes, two graders, two Tournapulls, one front loader, eighteen 15-ton dump trucks, ten dozers, and one or two crushers.

The most likely site for a rock-over-ice runway near McMurdo is at the transition from accumulation area to ablation area on the Ross Ice Shelf. This is the same general area that would be used for a runway on glacier ice, i.e. on a line running from Cape Armitage to Black Island, not far from where the old Outer Williams Field was located. Along the transition, the average annual accumulation/ablation is theoretically zero. The mean annual air temperature is probably about -18°C . Ice movement is relatively slow, and there are no significant crevasses. The closest sources of fill are Black Island and White Island, where surface stripping would probably have to be supplemented by quarrying. Since the natural ice surface is rough in this area, a haul road would have to be prepared, probably by planing.

At McMurdo station, the maximum depth to which 0°C temperatures penetrate into rock and gravel is about 2.5 ft (assuming no significant infiltration of water). It is estimated that 2 ft of fill would be enough for a stable runway on the ice shelf; 2.5 ft would certainly be adequate. For a 3,000,000-ft² runway with 2 ft of fill, the required quantity is 222,000 yd³. A gravel parking apron would increase the required amount of fill. However, the taxiway and parking apron could use either a thinner veneer of gravel, or snow rolled over ice. A basic runway would probably require about twice the amount of fill that went into the second ramp road in Greenland.

The required amount of fill could perhaps be reduced by placing insulation panels of rigid foam (extruded polystyrene) beneath the gravel paving. This technique has been used for roads in the Arctic.

If this concept has any appeal, simple experiments should be made to determine the minimum depth of fill for a stable runway.

V. SNOW RUNWAYS ON THE ROSS ICE SHELF

Site conditions

Existing snow runways for ski aircraft are located on the Ross Ice Shelf (McMurdo Lobe), about 6.5 nautical miles ESE of the main station. This is an area of net accumulation, with annual accumulation of roughly 2 ft of snow, or about 0.23 m of water equivalent (*precipitation* at McMurdo station is about 0.18 m of water). In other words, it is a permanent snowfield where anything on the surface becomes buried deeper and deeper as time passes. The density of the annual snow layer averages about 0.33 Mg/m^3 in spring, and it increases to over 0.4 Mg/m^3 by the end of summer. Summer temperatures are appreciably lower than temperatures at the main station. The mean annual temperature at the site is about -18°C . In mid-summer, daily mean air temperatures rarely reach 0°C .

In this area, the ice shelf is very thin at its seaward edge, say about 70 ft (20 m) thick, depending on whether the front has calved recently. The thickness increases with increasing distance from the ice front, and at the airport site it is perhaps about 150 ft (45 m) thick. Since the shelf in this area is nourished primarily by local snow accumulation, the thin ice near the seaward margin is actually permeable snow-ice at sea level, so that seawater can infiltrate horizontally, creating a sort of water table below which the ice becomes saline.

The vertical gradient of snow density near the surface is such that density increases less than 0.03 Mg/m^3 for a depth increase of 1 m, so that naturally occurring "strong" snow is far too deep to be of practical use.

In summer, solar radiation is strong, and of long duration. Sunny days are common. All types of surface snow lose strength because of the high temperature in December, January and early February. For the rest of the year, all types of well-bonded snow are relatively strong.

Natural snow at the site is fine-grained material that is deposited mostly in windy weather. Blowing snow has a typical grain size of about 0.1 mm, but after deposition there is rapid growth of the small particles. By November, grain size in

the surface layer is typically in the range 0.5 to 1.0 mm.

The relatively high summer temperatures at the site give rapid sintering of processed snow (see Fig. VI-1).

NCEL procedure for snow processing

NCEL developed methods for producing strong pavements of snow. Much of the development was done at the McMurdo skiway site and on nearby snow-covered sea ice, and the results are well documented in NCEL reports.

The natural snow is mixed and milled by a rotary tiller called a Pulvimixer (Fig. V-1). Two passes are made over the entire processing area. The surface is leveled by ski-mounted land planes (snow planes), which are essentially long graders that lack self-propulsion (Fig. V-2). The snow planes are towed by crawler tractors. Simple drags are used for grooming the surface. The surface is compacted by rollers. One type of roller, normally used on relatively soft snow, is an 8-ft-diameter, smooth steel drum, 8 ft wide, applying a weight of about 5 ton. The other type of roller is intended specifically for surface hardening. It has 13 pneumatic-tire wheels on two axles, and its ballast cart can give total loads in the range 11 to 13 ton. In recent years, special off-road trucks with fairly smooth balloon tires have been used by ANS for surface hardening on snow roads at McMurdo.

The NCEL process is capable of making a runway that can carry wheeled aircraft under favorable conditions. However, there is not much reserve of strength and quality-control problems can leave occasional soft spots in the runway.

NCEL used sawdust to cover snow pavements when parking areas were made for the 1960 Olympic Winter Games at Squaw Valley.

SIPRE (CRREL) procedures for snow processing

Experimental snow runways were built in Greenland by SIPRE (forerunner of CRREL).



Figure V-1. NCEL Pulvimixer towed by small tractor.

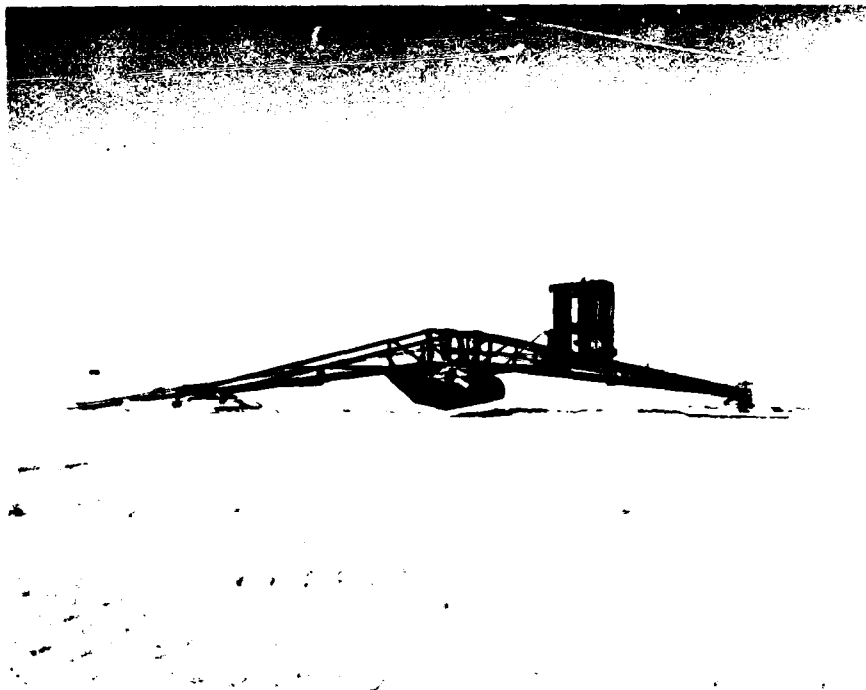

Figure V-2. NCEL 40-ft snow plane.



Figure V-3. SIPRE rotary snow plow adapted for runway processing.

Natural dry snow was milled by rotary snow plows that had special back-casting chutes (Fig. V-3). The cuttings were re-deposited to give a layer that was fine-grained, dense, and homogeneous. In some cases, the freshly-deposited processed snow was subjected to vibratory compaction. The surface was leveled by using various ski-mounted graders and drags. Steel rollers, either smooth or corrugated, were used for surface compaction.

The SIPRE technique gave more uniform, and more finely-ground, snow than the NCEL technique, but it employed equipment that was more expensive and more troublesome than the Pulvimixer. Again, the snow pavement was capable of supporting wheeled aircraft under favorable conditions, but without a comfortable reserve of strength and without a guarantee of fully adequate strength over 100% of the runway area.

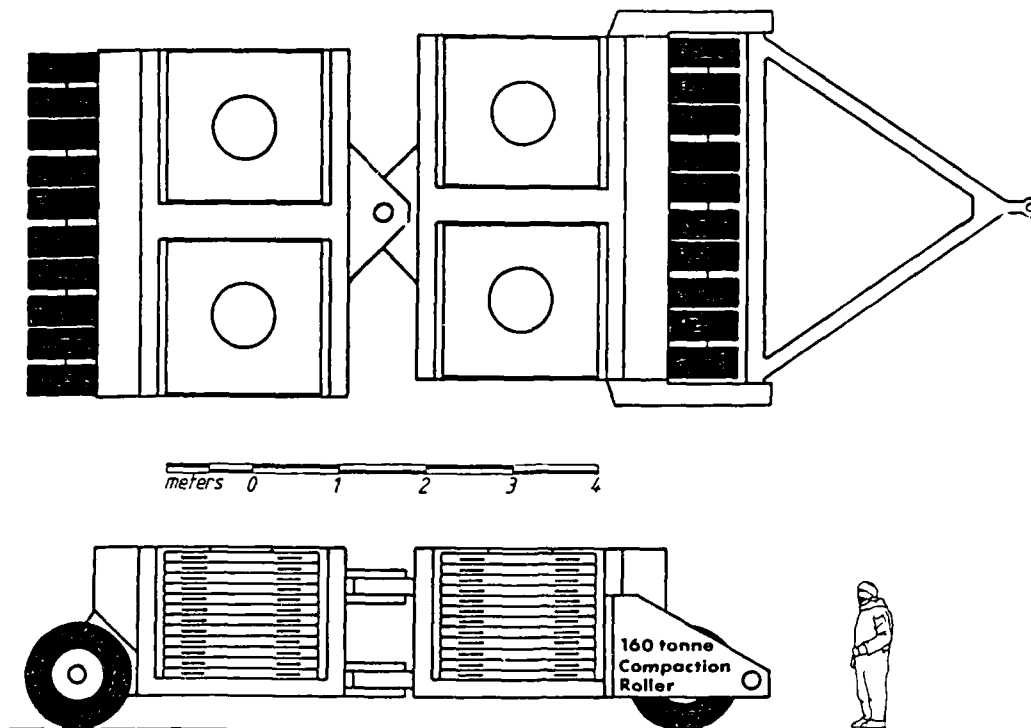

COMPACTION ROLLER

Outline Specifications

ROLLER TYPE Towed multi-tyre pneumatic

TYRES:

Type Smooth compactor type
 Size 13.00 x 24 - 26 ply
 Pressure 1000 kPa max
 Number two rows of 10

AIR SYSTEM:

Type Through axle supply
 Control Regulator to each axle pair
 Range 100 to 1000 kPa

WEIGHTS:

Empty 40 000 kg
 Fully laden 160 000 kg
 Load weights 2 500 kg stackable
 Load handling fork lift

DIMENSIONS:

Roll width 4 m approx
 Turning circle 20 m max
 Tyre spacing 100 mm max
 Tyre offset 100 mm approx
 Wheel base 7 m
 Overall width 4.6 m
 Length ex drawbar 8.2 m
 Length overall 11.2 m

TRANSPORTATION: Disassembles into <10 tonne parts
 Parts transportable by C-130

Figure V-4. Heavy roller proposed by Australian engineers.

Soviet/Australian method for snow compaction

Soviet engineers experimented with snow processing, heat treatment and compaction in the sixties. As far as is known, the method that was finally adopted for snow runways in Antarctica was a very simple procedure, involving only rolling with multi-tire rollers and grading with a special planer. The key to success seems to have been site selection and timing of the construction work. The goal is to have a site that is warm enough in summer to give moist cohesive snow, but not so warm that the finished runway thaws or softens excessively. However, it is reported that the snow runways at Molodezhnaya and Novolazarevskaya do have to close in December, January and early February. Frequent rolling is continued throughout the winter, so that new snow is incorporated into the pavement.

In 1983/84, Australian engineers undertook experimental runway construction near Casey station, which is about 1,850 nautical miles from Hobart. The experiences of both U.S. and Soviet engineers were taken into consideration in developing a fairly simple procedure. The natural snow was milled and cast into place by a rotary snow plow. The surface was leveled by a laser-guided grader, and it was compacted by a multi-tire roller. The Casey site is a favorable one for snow compaction, and surface tests indicated that the finished pavement could support a fully-loaded C-130. Complete details of the Australian findings are given in a separate report (*Compacted Snow Runways*, by D. S. Russell-Head and W.F. Budd).

Australian scientists and engineers who were associated with the Casey project are highly optimistic about the prospects for making a snow runway with heavy rollers, especially at McMurdo and possibly also at the South Pole. They propose construction of a two-axle multi-tire roller (Fig. V-4) that can be ballasted up to a total weight of 160 tonne (176 ton). The inflation pressure of the tires is adjustable within the range 0.1 to 1.0 MPa (14.5 to 145 lbf/in.²). The idea is that rolling will start with low tire pressure and low total load, with both increasing in increments up to the maximum values, which are close to the gross weight and tire pressure for a large transport aircraft. The rolling width of this device is to be 4 m (13.1 ft).

Surface paving on snow runways

Any of the foregoing methods will produce snow that is strong enough for the base course of

a major runway. At a sufficiently warm site, the Soviet/Australian method will also provide a hard surface, although such a site may cause operating problems in mid-summer. However, for the Ross Ice Shelf near McMurdo Sound, there is no guarantee that any of these methods will provide a surface that resists rutting by high-pressure tires on heavy aircraft. A separate technique for paving the surface is probably needed.

The broad possibilities for surface paving on a snow runway have been discussed in some detail in Section VI, which deals with South Pole runways. However, the climate at McMurdo is much milder than that at the South Pole, water is much easier to produce, and heavy materials can be delivered directly by ship.

Manufactured landing mats could be considered at McMurdo, since shipping weight is not a major concern for this site. To surface a 10,000 x 300 ft runway with the AM-2 system, the cost of the materials would be about \$51 million (see article on Airfield Landing Mats in Section VI).

The *high pressure paving machine* described in the South Pole section, and in Appendix D, is not considered justifiable for McMurdo, since there are less expensive and less complicated alternatives.

An *iced pavement produced by water* is economically feasible at McMurdo, provided that the technical problems of introducing water into the snow, or of placing water, or snow/water slurry, on the surface can be dealt with. In summer, fresh water can be piped from the lake above McMurdo station, while sea water can be lifted directly through drill holes by submersible pumps. To use the water, the simplest approach would be to *spray the compacted snow* surface directly, controlling application rates so as to avoid gross overloading of the capillary retention capability of the snow. A *snow/water slurry* could be mixed and placed if suitable paving machines were developed. *Surface flooding* with 100% water seems neither necessary nor desirable, since low density snow-ice has ample strength and it has more favorable optical properties than clear ice of high density (it reflects more solar radiation and thus resists melting).

An *iced pavement produced by heat* is feasible in principle. The most attractive energy source is *solar radiation*, which can be collected most easily by darkening the surface of the compacted snow. Experimental *heat injectors* used by the U.S. Army in Greenland around 1960 were unsuccessful because the heating of the snow was

not uniform (intense heat at the injector nozzles, cold snow between them). Injection of heat into a rotary snow mixer was tried in a Soviet experimental machine, the STM-2. As far as is known, this device has not been used for full-scale runway construction.

Sawdust additive, discussed in Section VI, may be capable of strengthening the snow and giving it enough bearing capacity to support wheeled aircraft. The hardened snow/sawdust mixture would probably require a thin cover of clean snow to protect it from solar radiation in summer. Annual renewal of the treatment would necessitate a large stockpile of sawdust, and equipment for mixing sawdust into the snow that accumulates during winter. It is not yet clear how the operation would be phased so as to permit both treatment of the runway and air operations in summer.

Tentative conclusions concerning snow runways at McMurdo

Because there is substantial annual snow accumulation at the site, the surface of the runway will have to be renewed every year. This seems to

rule out the surface paving methods that are complicated and/or expensive.

Initial construction of the base course is straightforward and relatively inexpensive. The essence of the problem is to make a surface pavement by a simple and inexpensive method that can be repeated, possibly every year and certainly at intervals no greater than once every two years.

At present, there is no developed capability for making an iced pavement on compacted snow. The most promising line of development for McMurdo may be a combination of water spray and heavy rolling. A complicating factor is that the annual renewal of the pavement really needs to be done in late winter, before heavy traffic begins, but this is a bad time for compacting snow. Scheduling the job for mid-summer may not be feasible, even with closure of the airport, since the winter snow accumulation has to be dealt with before the heavy traffic of springtime begins.

Taking these various factors into consideration, it seems necessary to have a maintenance procedure that can be applied frequently and at almost any season, perhaps after every major increment of snow accumulation.

VI. SOUTH POLE SNOW RUNWAY

Site conditions

Snow depth at the South Pole is effectively infinite. The annual net accumulation averages about 6.8 g/cm^2 , which is equivalent to 6.8 cm of water. The average bulk density of the snow in the surface layers is about 0.36 Mg/m^3 . The thickness of the snow layer that is added each year by natural accumulation in undisturbed areas is about 19 cm, or about 7.4 in. The vertical gradient of density is small, with densities of about 0.432 and 0.494 Mg/m^3 at 5 m and 10 m depths respectively. The average density in the top 2 m of snow is about 0.375 Mg/m^3 .

The site is very cold, with a mean annual temperature of about -50°C . In summer, the mean daily temperature rarely gets above -25°C . In winter, the daily mean temperature can get down to -80°C .

In summer there is continuous daylight and, for much of the time, continuous direct sunlight. The high elevation of the site, about 2,800 m, means that there is only a small part of the earth's air mass to absorb solar radiation. The net result is that the South Pole has a very high input of solar radiation in summer.

Winds are light and persistent, with little change of direction. Very high winds are almost unknown.

Snow properties

Deposited snow at the South Pole is fine-grained, with particle size of order 1 mm. The snow is very dry as a consequence of the low site temperature. On each snow grain, the surface layer of relatively mobile molecules is almost inactive, and even in dense snow there is very little tendency for the grains to stick together and to develop intergranular bonds by vapor diffusion and surface diffusion of water molecules (i.e. sintering is very slow). Figure VI-1 indicates the relative rates of sintering, or "age-hardening," in dense snow with isothermal environments of -50°C and -10°C .

In general, the strength of dry snow is very strongly dependent on its bulk density, or porosity (Fig. VI-2). Because the natural snow at the South Pole has low density, it is quite weak, in spite of the low temperature. This is emphasized by a plot of strength against density on linear scales (Fig. VI-3). Even when tested at -50°C , the

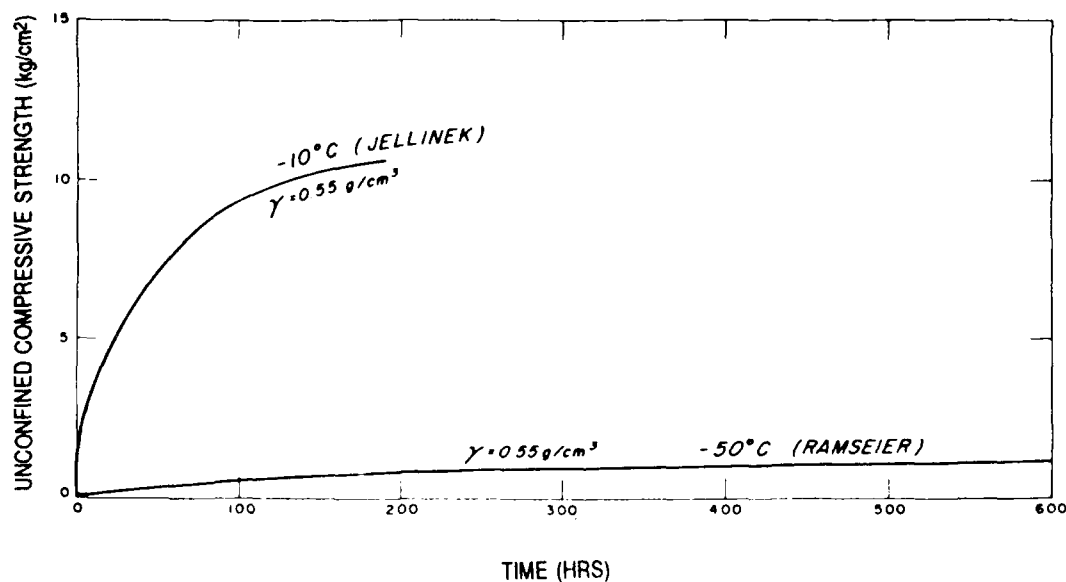

Figure VI-1. Uniaxial compressive strength of snow as a function of time during the sintering period (data from Ramseier and Gow, 1965, and Jellinek 1957).

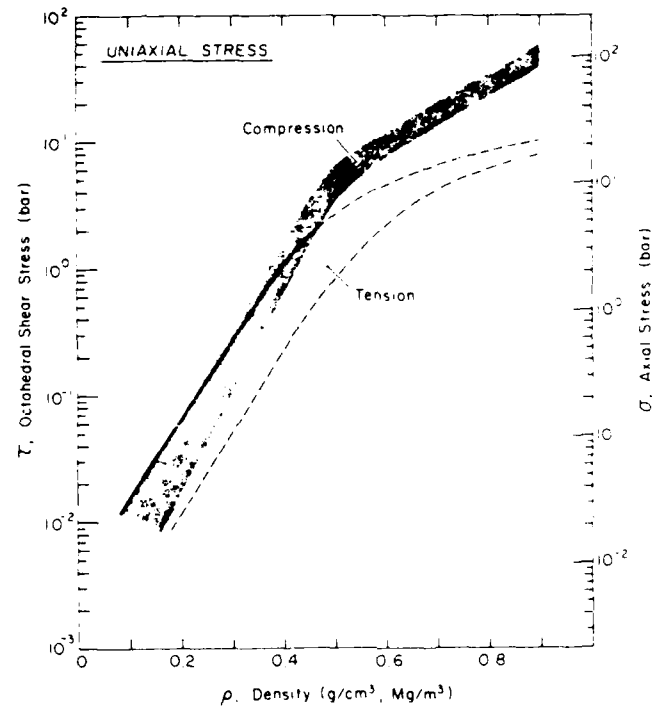

Figure VI-2. Variation of the strength of dry snow with the bulk density (Mellor 1975).

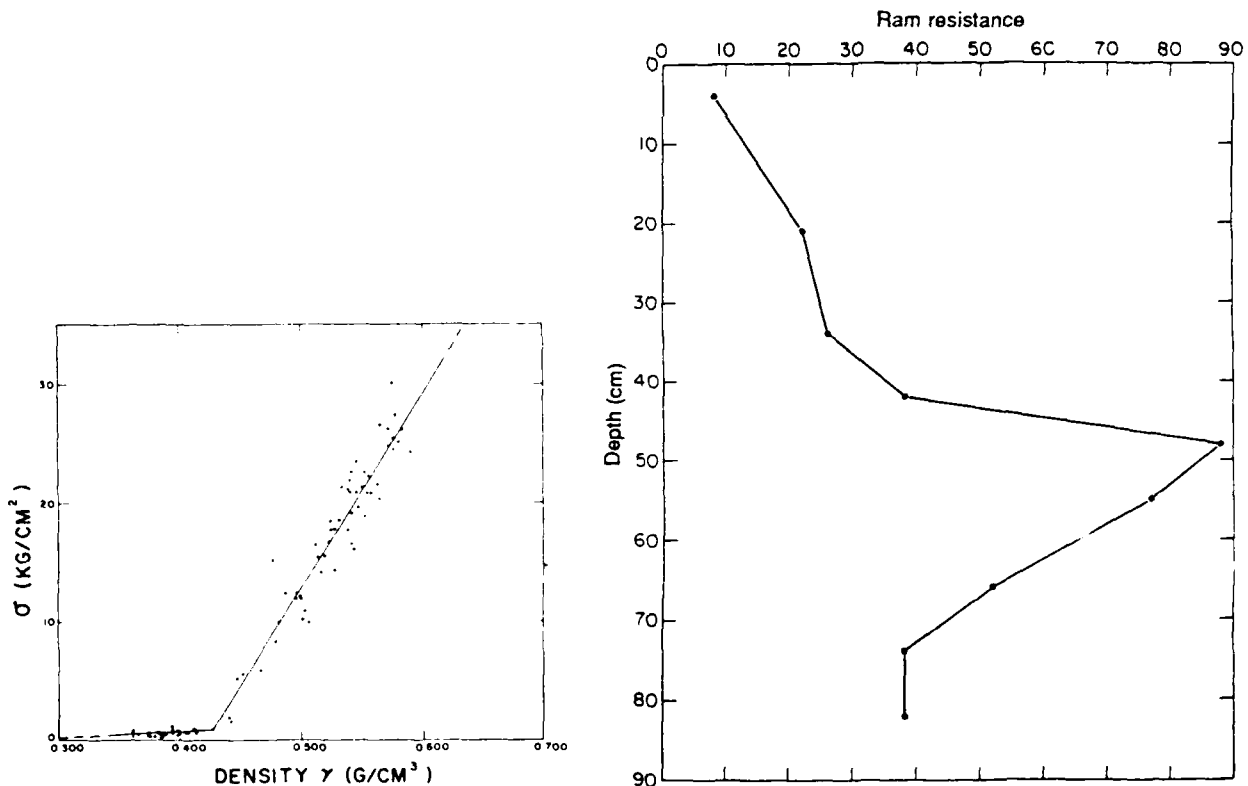

Figure VI-3. Uniaxial compressive strength of natural South Pole snow plotted against bulk density (test temperature -50°C) (Ramseier 1963).

Figure VI-4. Penetration resistance as a function of depth in South Pole snow (from measurements by Lee, Haas and Wuori 1986).

South Pole surface snow has a uniaxial compressive strength that typically is only around 8 kPa (11 lbf/in.²).

Rapid field measurements of snow strength are often made by driving an impact penetrometer called a Rammsonde. Figure VI-4 gives an impression of the Ram resistance in the surface layers of natural snow at the South Pole.

Snow compaction to support wheel traffic

Natural snow at the South Pole is far too weak to support heavy loads on high pressure tires. In the surface layers, both the uniaxial compressive strength and the ram resistance are more than an order of magnitude too low to support a C-130 or a C-141 on wheels. For operation of the C-141, the compressive strength of the surface snow needs to be brought up to about 200 lbf/in.² (1.4 MPa), with ram resistance around 1,000. In order to achieve this kind of strength, two things are needed: (1) increase the snow density to values above 0.5 Mg/m³, (2) form bonds between the snow grains.

One obvious way to compact is by *rolling*, and this technique is treated in detail in a separate report ("Compacted Snow Runways," by Russell-Head and Budd, 1988). However, it is far from certain that rollers can achieve the desired result at the South Pole. It is quite possible that rollers will crush a relatively thin surface layer until it becomes a loose and cohesionless granular mass, with some of the characteristics of dry beach sand. Ideally, the snow should be "moist" (i.e. cohesive) for efficient rolling, a condition that does not normally exist below about -10°C (at temperatures above -10 C there is a "liquid-like" layer on the ice grains). To give the snow cohesive characteristics at very low temperature, very fine grinding or addition of a melting chemical are possibilities.

There are two inherent problems with direct mechanical compaction: (1) the depth of compaction is directly related to the bearing area of the compactor, (2) high pressure over a large area is difficult to achieve by deadweight. The ideal roller for deep compaction of snow might be a very wide crawler track whose bearing pressure could be controlled from about 10 lbf/in.² to 200 lbf/in.². On a bearing area of 100 ft², this implies a dead-

weight of up to 1,440 tons! A contraption with this weight would not be easy to pull.

In order to apply high force to a large bearing area, it is necessary to use inertial forces instead of deadweight. A separate proposal for an *impact device* has been prepared as part of this study (Appendix B). One version of the device uses a simple drop-weight, while another version applies multiple blows to the compaction box with a diesel pile-driving hammer. High frequency impact by vibratory compactors is not likely to compact thick layers.

Another way to compact dry snow is to *commi-nute* it, ideally into its constituent grains or even smaller fragments, and then redeposit the loose material so that it achieves the characteristic close packing of dry granular material (upper limit of about 0.55 Mg/m³, or 40% porosity, when the grains approximate to uniform spheres). One method uses rotary soil-tilling machinery to mix the snow, more or less in place. The most successful device of this kind has been the *Pulvimixer* used by NCEL. Another method uses *rotary snow plows* to mill the snow and eject it, either into free air or into a special chute. This method was used extensively by SIPRE/ CRREL and others. A refinement of the milling method has been developed for this project, as described in a separate document (Appendix C). It uses a special machine to comminute the snow to very fine grain size and to redeposit the grains immediately, without exposing them to free air. If there is a fairly broad range of grain sizes in the milled snow, and if the grains are well mixed, the initial density should be relatively high. The finest grains should promote relatively rapid sintering.

The runway surface really ought to be made very hard, so as to avoid rutting and minimize rolling resistance. Ideally, the surface slab ought to have very high density, say around 0.65 Mg/m³. This is virtually impossible to achieve with conventional compaction of dry snow that has equant grains, since a density of 0.55 Mg/m³ is the limit of what can be reached without fracturing or deforming the grains themselves. A concept for *squeezing slabs of dry snow* at pressures up to 300 lbf/in.² has been developed as part of this project, and a suitable machine has been designed (Appendix D).

Sawdust additive

Mixing sawdust into milled snow in the proportion 5% to 10% by volume has been found to strengthen the snow considerably.* It is not yet known exactly how this strengthening takes place, but it seems likely that lowering of the albedo, with consequent increase of radiation absorption, is a significant factor. The fibrous nature of the sawdust, together with the water absorbency, may also contribute to the bonding between the ice grains and the sawdust.

A research team from the Keweenaw Research Center considered that a sawdust mixture about 0.7 m deep would be appropriate, with the mixture containing 5% to 10% of sawdust. From a practical standpoint, this seems an unacceptably large amount of sawdust. The required total volume of loose sawdust might be around 20,000 yd³, which could call for more than 400 flights by LC-130 aircraft. It would be somewhat more practical if the sawdust were compacted into dense bales and free-dropped by a bigger aircraft.

If sawdust were used only in a pavement layer, say 0.25 m thick, the required quantity would be more manageable, say 3,500 to 7,000 m³, or 4,500 to 9,000 yd³.

A major drawback to this concept is the requirement for periodic renewal of the surface paving, which implies that new supplies of sawdust would have to be flown in from time to time.

Methods for inducing intergranular bonding in dry snow

At snowfield sites that are less frigid than the South Pole, fine-grained dry snow will develop intergranular bonds naturally.

When snow has been drifted by the wind, or has been milled by a rotary snow plow, the grains are small and more or less equidimensional. They pack together closely, having multiple contacts with each other. Because the surface molecules of an ice grain are not fully bonded into the lattice structure of the ice crystal, they can attach to the

molecules of another grain to give an immediate, but weak, adhesive bond. However, the mobility of molecules in the surface layer decreases as temperature decreases, and at South Pole temperatures there is virtually no immediate adhesion when 1 mm ice grains are brought into contact.

At the relatively mild temperatures of Greenland, or of low elevations in Antarctica, a well-packed mass of fine-grained snow develops progressively stronger intergranular bonds as time goes by. The mobile surface molecules move into the areas of contact by vapor diffusion, and to a lesser extent by surface diffusion, rounding off sharp corners, filling-in concavities, and completely eliminating the smallest grains. The process, known as *sintering*, or *age-hardening*, causes fine-grained snow to gain strength with time, rapidly at first and then tailing off to an asymptotic limit. However, the rate of the hardening process is temperature-dependent, and it becomes extremely slow at very low temperatures.

Figure VI-1 gives an idea of how slow the sintering process becomes with a uniform temperature of -50°C. Taken at face value, this kind of experiment leads to very pessimistic predictions for age-hardening in a snow runway at the South Pole, but there are reasons for believing that age-hardening will progress at significant rates under natural conditions. The natural snow surface experiences temperature variations, it absorbs solar radiation, and air movement in the pores is stimulated by winds. These things give rise to potential gradients that can drive vapor diffusion processes, and thus promote age-hardening. Nevertheless, sintering of ordinary milled snow is likely to be too slow unless the snow temperature can be increased significantly.

One way to accelerate sintering is to process the snow so that it has a high proportion of very fine grains. The machine described in Appendix C is designed to do this by comminuting snow to very fine grain size, using sharp blades on a rotor that spins rapidly while the machine travels forward very slowly. The resulting material should be surface-active and cohesive at quite low temperatures. It should have good packing characteristics.

For warming the snow, the most appealing energy source is solar radiation. A clean, fresh snow surface reflects about 90% of the incident solar

*See "Improving snow roads and airstrips in Antarctica" by S.M. Lee, W.M. Haas, R.L. Brown and A.F. Wuori, Final Report on Contract DPP 86129521, Division of Polar Programs, National Science Foundation, May 1988.

radiation, so it might be desirable to darken the snow during the construction period, say by dusting it with a black powder. This alone might not be enough, since the wind is always trying to cool the surface to the air temperature. If it could be arranged, a sheet of clear plastic over the darkened snow surface ought to have a very significant effect in trapping solar energy and warming the snow. However, great ingenuity would be needed to find a practical way to anchor the sheets against wind disturbance. The edges of the sheets might have to be pushed down into slots, and some kind of cord-and-peg system would be needed to secure the sheets against billowing and flapping.

Inducing melt-freeze bonds by heating or wetting

Most people have seen how snow is strengthened by thaw-freeze or by rainfall followed by freezing, and the idea of adding water to the South Pole snow seems logical at first sight. However, on closer examination, uniform wetting of cold snow turns out to be quite difficult; past attempts to add water or to heat the snow were unsuccessful in Greenland field trials. There are two conflicting requirements: (a) introducing the water slowly enough to keep the distribution uniform, and (b) introducing the water rapidly enough to achieve percolation before it freezes.

To get a feel for wetting problems, consider the two extremes of a water spray application in cold, dry snow. With a very fine spray that travels fairly rapidly, both the rate of application and the total quantity per unit area are small. The water will freeze on the snow surface almost immediately, forming a surface glaze with no significant penetration. By contrast, if the spray device has a high flow rate and slow travel, the snow surface will be drenched. Some water will freeze near the surface, warming the snow in the process, but much of the water will seep down into the snow before it freezes. Unfortunately, the seepage is unlikely to be uniform; the water is likely to find preferred flow paths, leaving dry snow between the seepage paths. Subsurface horizons with low permeability block the vertical seepage and force sideways movement and accumulation.

Figure VI-5 shows the results of a wetting experiment carried out on the Greenland ice cap by

W. Tobiasson of CRREL. Dyed water was sprayed on the surface, and the area was then excavated to reveal successive horizontal levels, and also to give a section in the vertical plane. The horizontal plane at 3 in. depth has allowed much of the water to pass through, leaving pock marks that represent vertical "pipes." At 6 in. depth, a good deal of the water was retained and frozen in a very patchy pattern. At 9 in. depth there is still plenty of infiltration and freezing, but some areas are still white and apparently free from infiltration. At 12 in. and 15 in. some water has penetrated, again with a patchy distribution. The vertical section indicates that crusts inside the snow influenced the movement of the water.

Snow can hold a small amount of liquid water by capillarity. The limiting amount is about 3% by volume.* If this quantity is exceeded, the water seeps down under gravity. It might therefore be desirable to aim for a uniform dispersion of water at this concentration.

Suppose that water is to be added at 3% concentration to a 50 cm layer of dry snow which has an initial density of 0.55 Mg/m^3 . For each square metre of surface the total volume is 0.5 m^3 . The volume of water is therefore 0.015 m^3 , and its mass is 0.015 Mg, or 15 kg. For a 3,000,000-ft² runway, the required amount of water is $4.1 \times 10^6 \text{ kg}$, $9.22 \times 10^6 \text{ lb}$, or 1.1 million gal. If this water is to be produced by melting snow that is initially at -30°C , the heat required is $1.66 \times 10^{12} \text{ J}$, or $1.57 \times 10^9 \text{ Btu}$. If the heat is produced by burning DFA in a system that has 100% thermal efficiency, we need $8.07 \times 10^4 \text{ lb}$ of fuel, or 11,300 gal. Taking a more realistic value of 50% thermal efficiency, the fuel required is 22,600 gal., or about one storage bladder.

This calculation shows that addition of water at 3% concentration is affordable in terms of fuel expenditure. The main practical problem is how to mix the dry snow and the water to achieve a uniform dispersion. The best bet might be to mix the snow and the water mechanically in a milling operation.

*To get the density of the wetted snow in Mg/m^3 , add 0.03 Mg/m^3 to the original density of the dry snow.

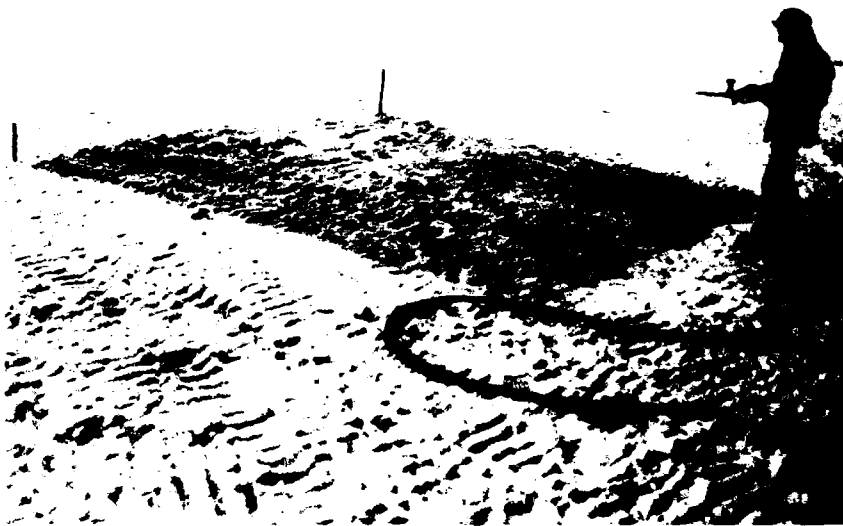

a. Surface spray.



b. 3 in. depth.

Figure VI-5. Penetration of dyed water into dry snow at DYE-3, Greenland, 1975. A 15 ft x 15 ft area was sprayed and the snow was excavated to see how the water had infiltrated (photos by W. Toljasson).

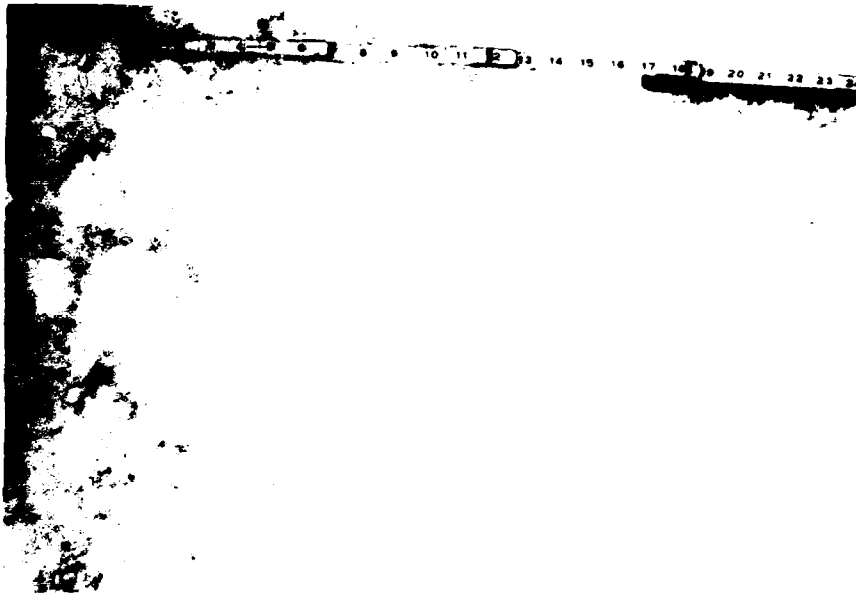

c. 6 in. depth.

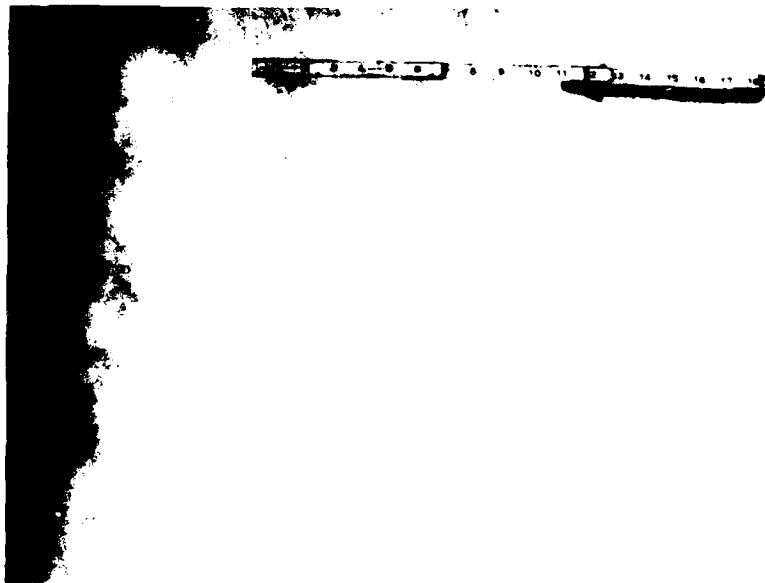

d. 9 in. depth.

Figure VI-5 (cont'd). Penetration of dyed water into dry snow at DYE-3, Greenland, 1975. A 15 ft x 15 ft area was sprayed and the snow was excavated to see how the water had infiltrated (photos by W. Tobiasson).

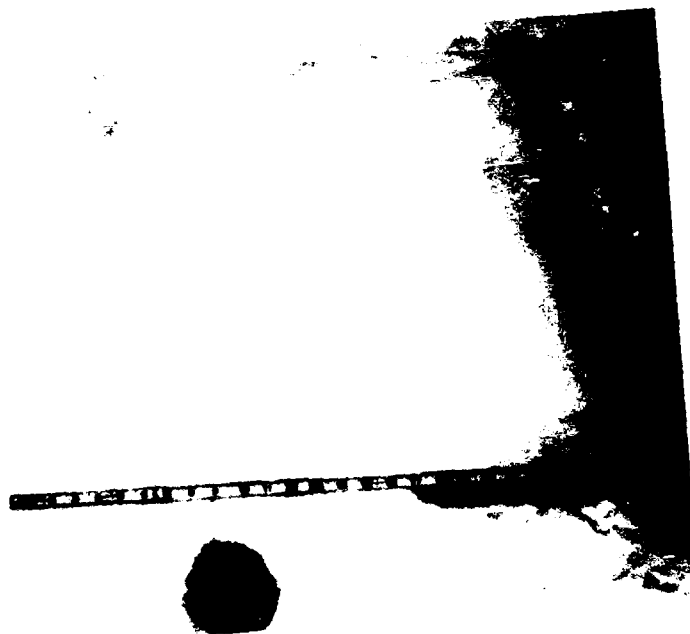

e. 12 in. depth.

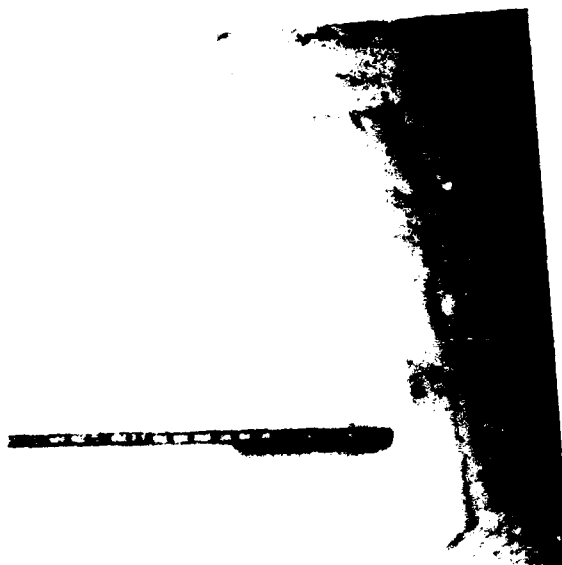

f. 15 in. depth.

Figure VI-5 (cont'd).



g. Vertical cross-section.

Figure VI-5 (cont'd). Penetration of dyed water into dry snow at DYE-3, Greenland, 1975. A 15 ft x 15 ft area was sprayed and the snow was excavated to see how the water had infiltrated (photos by W. Tobiasson).

Chemical additives

Another possibility for inducing wetness and for making thaw-freeze bonds is to add a chemical that depresses the freezing point. This seems to be a new idea, and there has not yet been time for systematic study. The idea is to disperse a suitable chemical, either a powder or a liquid, in the snow. Melting will occur until the equilibrium concentration for the prevailing temperature has been reached. The solution will re-freeze when the ambient temperature is lowered. The idea is to choose a chemical with a low eutectic (e.g. calcium chloride, ethylene glycol, methyl alcohol) and disperse it in the surface layer of the snow just before the midsummer period. With ample solar radiation on a darkened snow surface, the near-surface snow should become moist and cohesive, permitting efficient compaction by rolling. When that layer becomes buried by new accumulation it should freeze hard, providing a strong base layer to facilitate compaction of the overlying snow.

To get a feel for the required quantities of chemical, assume an equilibrium melting ratio of 2.5 (mass of ice melted per unit mass of chemical). This seems to be about right for calcium chloride at -30 to -35°C (the eutectic is about -51°C). If we

require water at the 3% volume concentration, as discussed above, the ratio of water mass to total mass is $0.03 \rho_w / \rho_s$, where ρ_w is water density and ρ_s is snow density. With a snow density of 0.55 Mg/m^3 , the mass ratio for the water is 0.0545. With a melting ratio for the chemical of 2.5, the required mass of chemical per unit mass of snow is 0.0218, i.e. about 2%.

Although the chemical additive is seen as something to modify fairly thin layers ($\leq 0.25 \text{ m}$), we can make the calculation for a 0.5 m layer to permit comparison with the foregoing estimate for melting by oil-fired heating. For each square metre the required amount of water is again 15 kg, which is melted by adding 6 kg of calcium chloride. Over a 3,000,000-ft² runway the required amount of chemical is then $1.67 \times 10^6 \text{ kg}$, $3.69 \times 10^6 \text{ lb}$, or 1,844 ton. This is nowhere near competitive with oil-fired heating. In fact, it is prohibitive as a bulk treatment.

There is an important difference between: (a) wetting by heating or watering, and (b) wetting by adding a freezing-point depressant. For (a), the temporarily moist snow cools and refreezes very rapidly, so that any compaction has to be done immediately in order to gain advantage from the moist condition. By contrast, (b) should

keep the snow moist and cohesive for many days, thus simulating a sustained warm spell and permitting repeated compaction of the moist snow. The practical question is whether or not it is feasible to provide enough chemical to do any good. If the snow can be made sufficiently moist with half the amount of water assumed in the previous calculation, i.e. with 1.5% volume concentration, then the required mass concentration of calcium chloride is about 1% of chemical in unit mass of snow. If the thickness of the treated layer is reduced to 0.25 m (\approx 10 in.) instead of the 0.5 m assumed previously, then the required amount of calcium chloride is 461 ton. The U.S. price for calcium chloride is \$265/ton, so this amount would cost \$122,000 at source.

At this stage, it appears that chemicals, perhaps in combination with a water-soluble black dye powder, would be useful for surface treatments, and for conditioning the snow prior to mechanical compaction.

Formation of an ice pavement

NCEL has proposed the construction of an ice pavement by *flooding the surface with melt water*. The idea is to produce water by melting deep inside the ice cap ("Rodriguez well"), then flooding the water in 4-in. layers over compacted snow that has been sealed by what is called a "water barrier". The proposal seen by CRREL provides few details of the field procedures.

The first question is how much fuel would be needed. For a 4-in. layer of water on a 3,000,000-ft² runway, we need 1 million ft³ of water, or 62.4 million lb (2.83×10^4 m³, or 2.83×10^4 Mg). If the water is to be produced in a well that is more than 10 m deep, the snow first has to be heated from -50° to 0° C. For 2.83×10^4 Mg, the required energy is $(2.83 \times 10^4) \times (2.12 \times 10^6) \times (50) = 3 \times 10^{12}$ J (2.84×10^9 Btu). The snow then has to be melted at 0° C. The energy needed for the phase change is $(2.83 \times 10^4) \times (333.6 \times 10^6) = 9.44 \times 10^{12}$ J (8.95×10^9 Btu). The total energy needed to produce the water for a 4-in. layer is 12.44×10^{12} J, or 11.79×10^9 Btu. If the heat is supplied by burning DFA at 100% thermal efficiency and transferring the heat at 100% thermal efficiency, the required amount of DFA is 6.05×10^5 lb, or 302 tons. This is 84,500 gal. To assume 100% overall thermal efficiency is unrealistic. At 50% overall thermal efficiency, the fuel requirement for a single 4-in. layer is 604 tons, or 169,000 gal. This is about seven fuel bladders, each of 25,000 gallon capacity. Taking an ef-

fective fuel cost of \$8 per gal., the fuel cost for a 4-in. layer is about \$1.4 million. If multiple layers of ice, each 4-in. thick, are needed, then the fuel and cost requirements become prohibitive.

At first sight, flooding may seem attractive because it is simple and positive. However, there are some significant practical complications. The first is the "water barrier," which must provide a perfect seal. Another is the need for contraction joints to avoid disorderly polygonal cracking during periods of rapid cooling.

The fuel requirements for an ice pavement can be reduced by substituting an *ice/water slurry* for 100% liquid water. If snow and water are mixed so as to produce a 50/50 mixture at 0° C, the resulting slurry can be poured and pumped. However, it requires continuous mixing to avoid separation of the ice and water by gravity. A 50/50 slurry contains more water than is really needed for an iced pavement, but as the water/ice ratio is reduced, the slurry becomes progressively less fluid and therefore less easy to handle. If there is equipment capable of handling, placing and screeding stiffer mixtures, say down to 20/80 water/ice ratio, the resulting pavement material would probably be strong enough for any wheeled aircraft.

Mixing machines have been developed for recycling asphalt concrete in place. These machines break out the old pavement by rotary milling, then mix the old material with fresh binder and re-lay the pavement. It may be possible to modify such machines so that they mix snow with water, then lay, screed and compact the mixture.

To get a feel for the fuel requirements in a *wet-snow paving project*, assume a mixture that is designed to give a final density of 0.68 Mg/m³. As a first guess, we assume that 1 m³ of the wet snow mixture contains 0.55 Mg of ice grains and 0.13 Mg of liquid water. If all the material has to be warmed from -30° C to 0° C, the sensible heat requirement for each cubic metre is $(0.68) \times (2.12 \times 10^6) \times (30) = 4.325 \times 10^7$ J. The latent heat needed for each cubic metre is $(0.13) \times (333.6 \times 10^6) = 4.337 \times 10^7$ J. The interesting point here is that it takes as much heat to warm up the snow to 0° C as it does to produce meltwater at 0° C. There is obviously an incentive to use solar energy to boost the temperature of the snow before the melting operation starts. If the pavement is to be 0.25 m (9.8 in.) thick, the total energy required for a 3,000,000-ft² runway is 6.04×10^{12} J (5.72×10^9 Btu). If this energy is supplied by burning DFA at 100% thermal efficiency, the required amount is

147 tons or 41,000 gal. At a more realistic, though perhaps still optimistic, value of 50% thermal efficiency, the pavement calls for 82,000 gal. of DFA. If fuel has an effective cost of \$8 per gal., the cost for this amount is \$656,000.

Airfield landing mats and related products

Expedient, or expeditionary, military airstrips can be developed by using special airfield landing mats, such as the AM-2 Airfield Landing Mat (Navair 51-60A-1, 1983). Other systems and products have the potential to be used as expedient surfacing for runways.

The basic unit of the AM-2 system is a hollow aluminum panel, 12 x 2 ft in area and 1.5 in. thick. There are also half-panels, 6 x 2 ft in area. The panels are laid on a prepared ground surface and connected together, with the joints staggered, as in brickwork. Each full panel weighs 144 lb, or 6 lb/ft². When the panels are packaged for shipment, the unit weight is about 6.3 lb/ft². Associated hardware (clamps, tiedowns, etc) raises the effective unit weight a bit more. Exact costs for the AM-2 system are not known, but it is believed that the unit cost is approximately \$17/ft².

The AM-2 matting is intended to be laid mainly on firm soil that has been compacted and graded. According to Navair 51-60A-1, "The final grading operations shall be sufficiently level so that mats when laid shall not vary more than 1/4-inch in height over a 12-foot distance. Hand raking may be required to accomplish this condition." In other words, the matting does not obviate the need for careful site preparation, including compaction and grading.

Military MO-MAT is a lighter and less expensive matting, intended primarily for expedient road surfaces on beaches and soft terrain. MO-MAT alone probably would not serve as runway surfacing for routine operation of heavy transport aircraft, but it could perhaps be incorporated into a hardened snow pavement. MO-MAT has a unit shipping weight slightly above 1 lb/ft² and the 1984 unit cost was \$14/ft².

Another product that has been considered for expedient roads on loose sand and soft soil is a polyethylene honeycomb material called Geoweb Sand Grid, or Geoweb cellular confinement (Fig. VI-6). Strips of polyethylene are welded together at intervals so that a honeycomb is produced when a stack of strips is pulled apart, accordion-

GEOWEB Structural Properties

1. Expanded Dimension	8 ft. x 20 ft. x 8 or 4 in.
2. Collapsed Dimension	11 ft. x 5 in. 8 or 4 in.
3. Panel Thickness Nominal	0.047 in.
4. Weight	114 and 57 lbs.
5. Cell Area	41 in. ²
6. Cell Seam Node Pitch	13 in.
7. Welds/Seam	7
8. Seams Tensile Peel Strength	300 lbs.
9. Installation Temperature Range	-16°F to 110°F

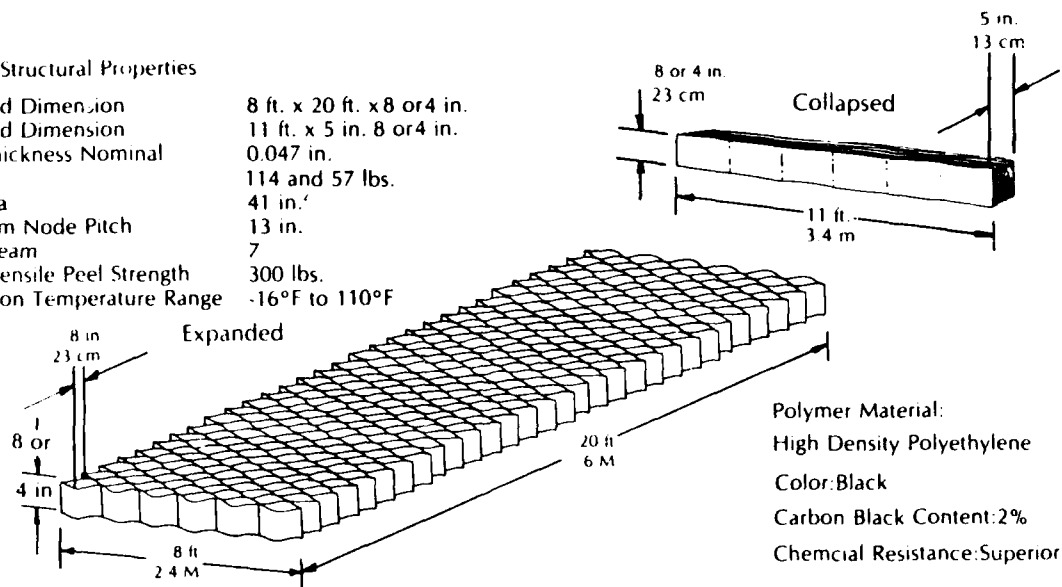

Figure VI-6. Polyethylene honeycomb used to stabilize loose soil.

fashion. The standard form of this plastic sand grid weighs about 0.71 lb/ft², and the cost is likely to be of the order of 10 cents/ft². On snow, the grid would have to be laid and pinned in place, then filled with snow, probably by rotary snow blowers. Practical details of the process are troublesome.

Exposed surface mats are not likely to survive the summer at McMurdo without disturbance because of melt problems. Many types of hard surfacing materials have been tried around McMurdo, and non-uniform melting has always occurred in summer, even with the materials painted white.

At South Pole, melting is not a problem with white-painted panels. The difficulty is that the matting will eventually be buried by the progressive snow accumulation. Thus the matting would have to be replaced or repositioned periodically, or methods would have to be developed for compacting snow against the hard surface of the matting, thus converting the runway to a processed snow strip.

The costs and weights of matting systems are formidable. Consider two sizes of runway: (a) 10,000 x 200 ft and (b) 10,000 x 300 ft. With the AM-2 system, the shipping weights are approximately 6,400 and 9,600 tons for (a) and (b) respectively. The corresponding basic costs for the equipment, excluding shipping costs, are about \$34 million and \$51 million for (a) and (b) respectively. Air freight from McMurdo to Pole would be about \$13 million for (a) and \$19 million for (b). Thus the use of AM-2 over such large areas would be prohibitive at the South Pole.

Using MO-MAT as part of a snow pavement, the shipping weights for (a) and (b) would exceed 1,000 ton and 1,500 ton. The basic costs, excluding shipping, would not be less than \$28 million for (a) or less than \$42 million for (b). Air freight from McMurdo to Pole would be about \$2 million for (a) and \$3 million for (b).

For plastic sand grid, shipping weights would exceed 700 ton or 1,000 ton for (a) or (b) respectively. Basic costs for the material would be of order \$0.2 million or \$0.3 million. Air freight from McMurdo to Pole would be about \$1.4 million for (a) and \$2 million for (b).

The optimum size of the labor force for installing matting systems depends on the operational scenario for the runway construction. As a first guess, it might number about 36 for actual assembly and installation of matting. This would allow for 20 hr/day working, and perhaps for short shifts.

Tentative conclusions concerning snow runways at South Pole

The first requirement is for a base course of high density snow, at least 0.5 m thick. If possible, this high density base layer should have significant intergranular bonding. The most practical and efficient way to achieve this is probably with a machine of the type outlined in Appendix C. A less attractive possibility is deep compaction by an impact machine of the type described in Appendix B.

Once a strong base course is in place, a hard pavement has to be constructed. Practical possibilities for building a hard pavement include:

- (1) The high pressure compaction machine outlined in Appendix D.
- (2) A wet snow pavement with about 20% of the total mass in the form of liquid water.
- (3) Rolling after fine grinding and/or chemical treatment.

Complete flooding with liquid water is not recommended. Dry processing alone (rolling, milling, sintering) is not considered likely to provide adequate quality control or a sufficient safety factor. Addition of sawdust is not recommended at this stage. Addition of melting chemicals may be worth investigating.

An important consideration is the requirement for periodic reconstruction of the pavement, perhaps every 2 or 3 years. Once a hard pavement exists, it is easier to pave over it than it is to pave on highly permeable snow. Water spray methods or chemical additives may become attractive for periodic maintenance and re-paving.

To induce bonding in the base course and to facilitate construction of a pavement, radiation absorption is highly desirable. Practical and economical methods for darkening the surface should be developed.

VII. INLAND RUNWAYS ON BLUE ICE

Blue-ice areas

"Blue ice" is a term used to distinguish areas of net ablation on polar ice caps. Most of the Antarctic ice sheet experiences net accumulation, and the resulting surface of fresh snow appears pure white. The few areas of net ablation reveal impermeable ice that was formed somewhere upstream, in the areas of net accumulation. The net ablation is caused primarily by wind, either katabatic winds in steeply sloping areas, or local surface winds funneled and accelerated by mountains, nunataks or significant surface relief. The ice in these ablation areas is bubbly, with density typically in the range 0.87 to 0.89 Mg/m³. Spectral selection in back-scattered light gives it a blue color, which is particularly noticeable in contrast to surrounding white snowfields. The albedo of the bare ice is lower than the albedo of fresh snow, so the blue-ice areas appear relatively dark in black-and-white photographs. The persistent strong winds that cause the ablation give the ice surface a cusped or rippled texture during the period when there is no melting, and other textures can be developed by solar radiation. Although wind is mainly responsible for the existence of blue ice, secondary ablation occurs by direct evaporation in winter (of order 0.5 mm/day), and by more vigorous melting and evaporation in summer (> 1 mm/day).

Blue-ice areas have long been recognized as potential landing areas for wheeled aircraft, with all-season availability in the colder places (say above 300 m, or 1,000 ft). Long stretches of fairly level ice are often available, and the small-scale roughness of the wind-cusps or ripples (of order 0.1–0.2 m diameter) gives good braking and steering. However, not all blue-ice areas are suitable as airfields, for the following reasons:

- (1) The ice surface is likely to have more slope and relief than open snowfields of the interior, since proximity to mountains or the coast gives relatively thin ice, with surface contours influenced by the rock-bed topography and the ice motion.
- (2) Persistent strong winds define takeoff and landing directions, create frequent heavy turbulence, and threaten parked aircraft.
- (3) Nearby mountains and nunataks can obstruct the approaches (a minimum glide slope requirement is about 50:1).

- (4) Meltwater channels, crevasses, or hard patches of sastrugi can spoil the surface.

Development of blue-ice airfields

In 1974, following suggestions for the reorganization of U.S. air operations in Antarctica, CRREL personnel made a study of blue-ice runways between South America and the South Pole. Air photos were studied, reconnaissance flights were made, and ground surveys were carried out in the Pensacola Mountains. Two suitable sites were located, one at 82°46' S, 53°40' W (Fig. VII-1, Fig. VII-2), the other at 83°15' S, 51°14' W (Fig. VII-3). Certain other areas were felt to be worthy of investigation, but they could not be inspected because of lack of time or because of unsuitable weather.

Also about 1974, two members of the British Antarctic Survey became interested in blue-ice areas south of the Antarctic Peninsula and, after retiring from BAS, in 1986 they used Landsat imagery to locate a blue-ice airfield (Fig. VII-4) at 80°19' S, 81°20' W (field elevation about 3,000 ft, or 900 m). Working with a private Canadian company, Adventure Network International, and its subsidiary, Antarctic Airways, they laid out two runways in December 1986, one 3,400 m x 50, the other 1,700 m x 50 m. The first flight with a DC-4 wheeled aircraft (as distinct from the ski-wheel Twin Otters used earlier) was made from Punta Arenas in November 1987, and revenue-producing passenger flights were started soon after. In January 1988, the field was used to fly in tourists and shuttle them on to the South Pole in ski-wheel Twin Otters. These commercial tourist trips to the South Pole could mark the beginning of a new phase in Antarctic air transport.

Blue-ice runways to support NSF operations

Many other blue-ice areas exist in the interior of Antarctica, and it is possible that there are suitable locations on the Ross Sea side of the Pole. The region around the head of the Beardmore Glacier seems a possibility; blue ice near Buckley Island and Plunket Point is one area that may be worth surveying to establish distances, approach slopes, and surface gradients. Of the regions that have the potential for providing blue-ice runways, the one closest to the Pole is the southern



Figure VII-1. Blue ice airfield at Rosser Ridge, Pensacola Mountains (Kovacs and Abele 1977).

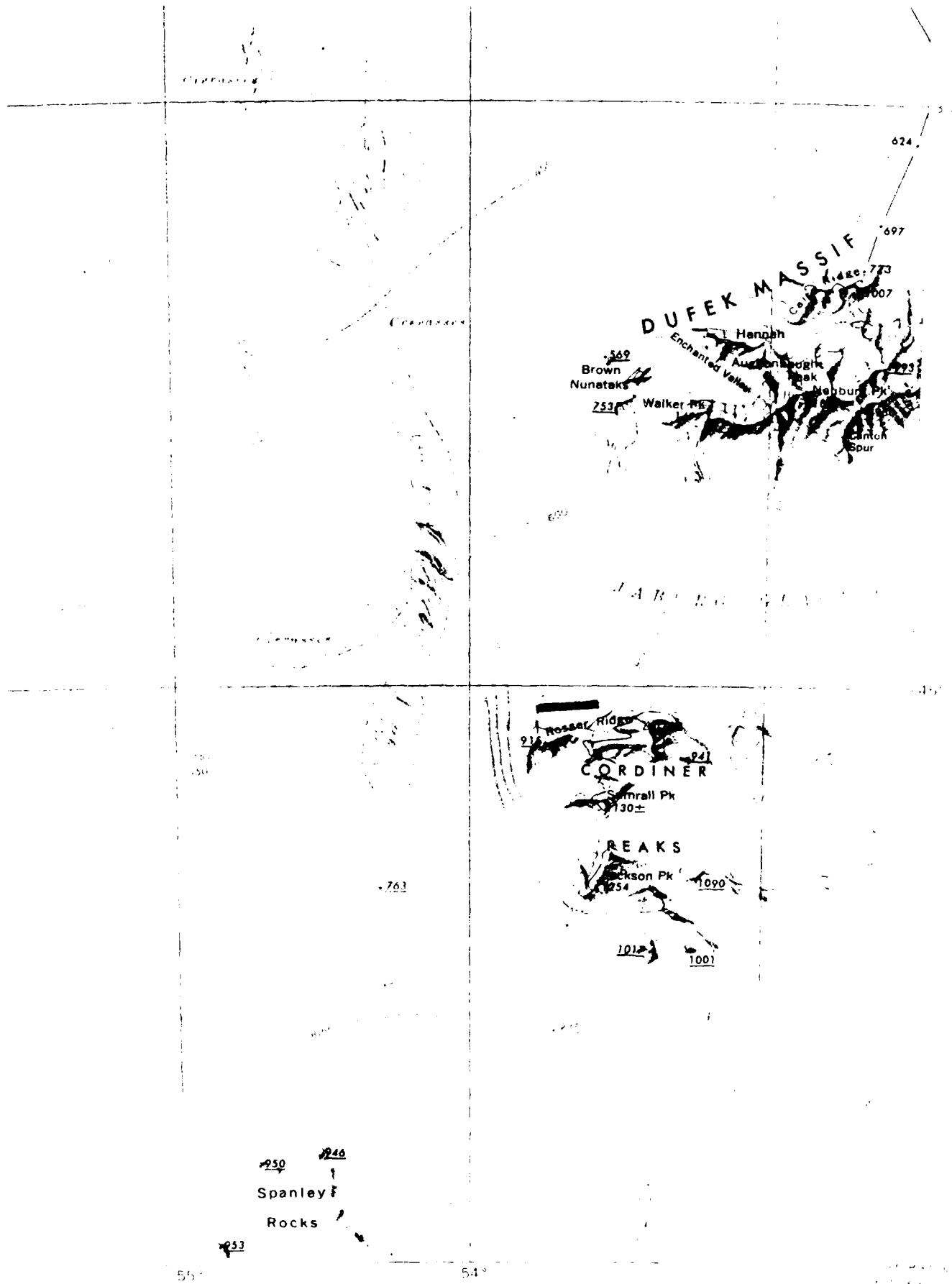

Figure VII-2. Location of blue-ice runway at Rosser Ridge.



Figure VII-3. Location of blue-ice runway at Mount Lechner.

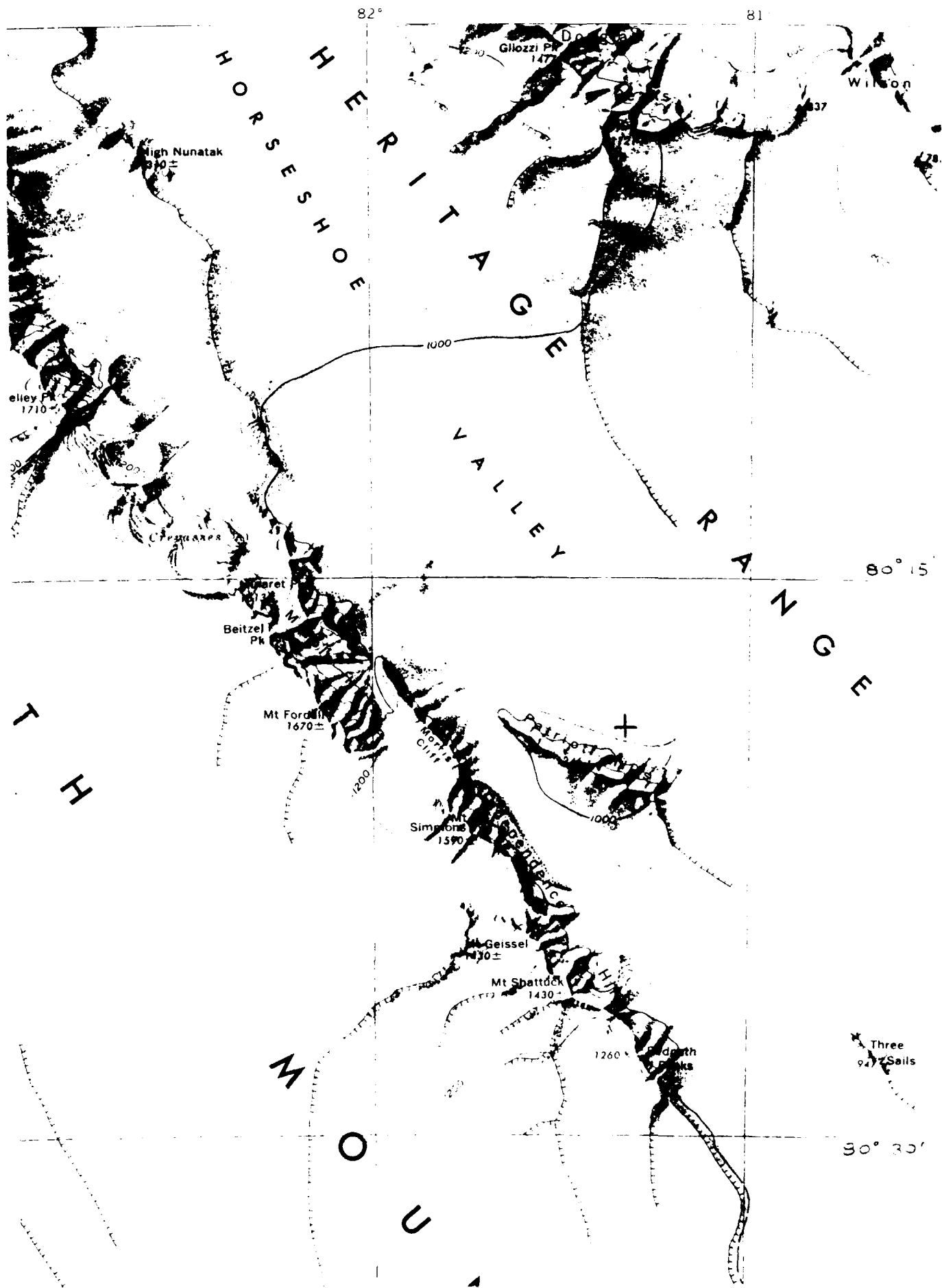

Figure VII-4. Location of blue-ice runway at Patriot Hills.

Queen Maud Mountains, say around 86° S and about 130° to 165° W. The Scott Glacier and the Reedy Glacier should be examined to see if they have suitable blue-ice areas, with initial focus on the area around Mt. Howe and d'Angelo Bluff (Fig. VII-5).

A satellite airfield within 250 nautical miles of the Pole could be useful. Supplies and passengers could be flown in directly from New Zealand or South America, or via McMurdo, in large wheeled aircraft. Passengers and priority freight could go on to the Pole by ski-wheel shuttle, with fuel and bulk cargo being transported by surface vehicles. This airport could support other inland stations, with locations such as Byrd and Siple, as well as field sites in the interior of East Antarctica.

The attraction of a well-chosen blue-ice runway is that construction and maintenance costs are almost nil. The cost of locating and surveying blue-ice landing fields is low. The first step is to use digitally-enhanced satellite imagery if any can be obtained for the target areas (Landsat and SPOT images do not extend far enough south to be

useful for locations south of 85° latitude). The next (or perhaps first) step is to use any existing photos of target areas. After air reconnaissance, the final step is field reconnaissance and survey by ground parties, using ski-wheel aircraft for trial landings.

Where good blue-ice runways are found, the U.S. should probably put in refuge huts and other minimal facilities suitable for establishing claims for future use.

No surface preparation is required for landing STOL aircraft. The DHC-6 Twin Otter is suitable for landing survey crews and light camp equipment. The primary maintenance task when operating large wheeled aircraft is removal of the scattered patches of sastrugi. This can be done by breaking up the sastrugi with a small snow plow and allowing the wind to disperse the fragments. It would be desirable to provide a tie-down area and a wind barrier for parked aircraft. Since blue ice is often close to exposed rock and moraine, facilities and fuel dumps can be set up on solid surfaces.

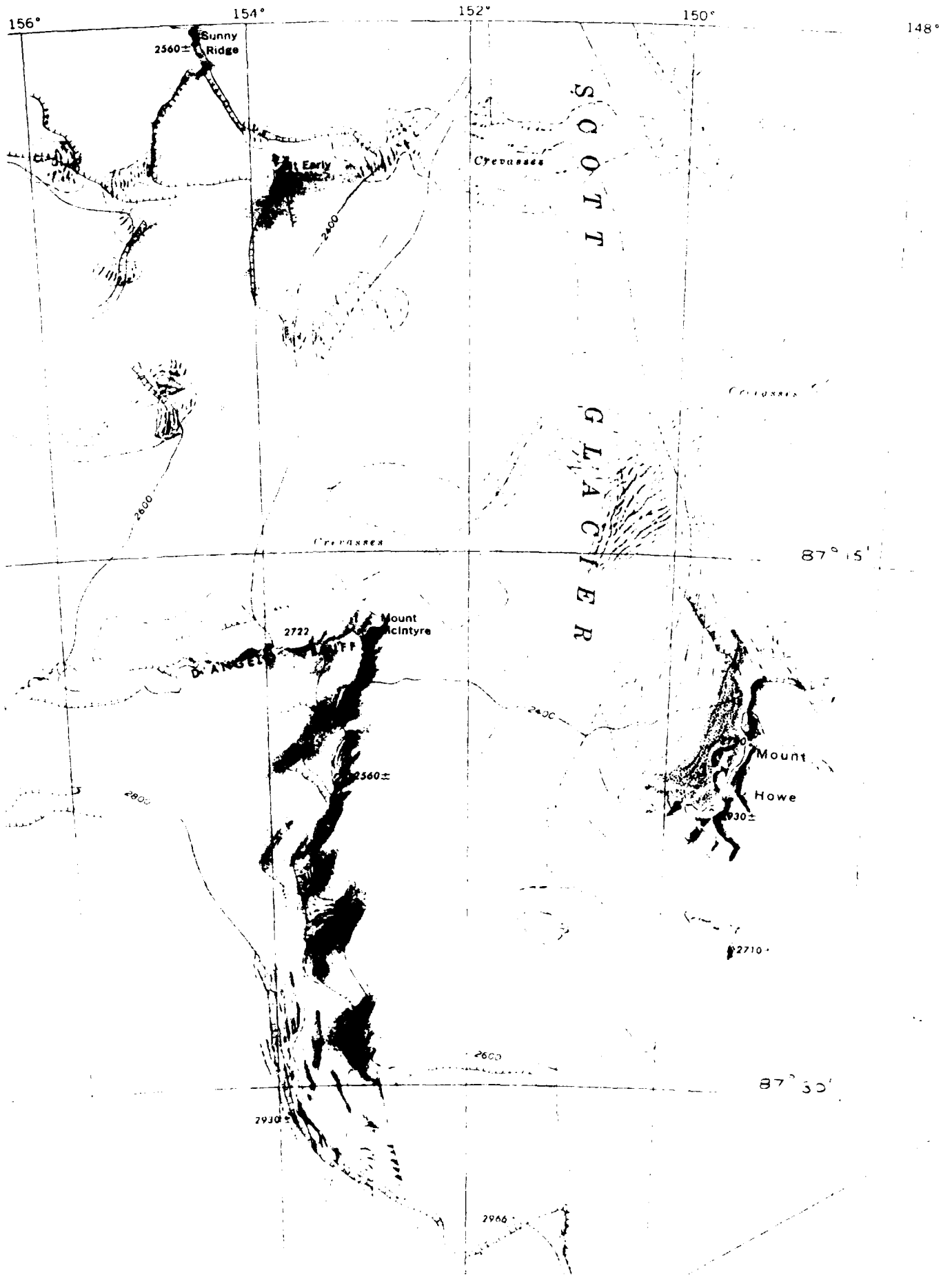

Figure VII-5. Surface features in the vicinity of Mt. Howe and d'Angelo Bluff.

VIII. COST CONSIDERATIONS

General

Detailed cost analyses are beyond the scope of this study, which is subject to limitations on time and budget. Since many of the runway concepts outlined in the report are likely to be rejected on technical grounds, detailed estimates for the concepts cannot be justified at this stage.

Many of the cost estimates given below are rough approximations at best, order of magnitude estimates at worst. If this seems too imprecise, it is worth recalling that professional cost estimates for some major projects of recent times have been off by almost an order of magnitude. The Alaska Pipeline, which was originally estimated to cost \$0.9 billion, came in at about \$8 billion, and major defense contracts commonly have enormous cost overruns.

There are various factors which complicate cost estimates for Antarctic projects, and the primary aim here is to alert professional estimators to some of these special considerations.

Fuel costs

Fuel delivered to Antarctica ought to be very expensive, as is fuel delivered to remote areas in other parts of the world. However, the fuel stored in bulk at the McMurdo tank farm is the property of the Defense Department, and it is sold to NSF at the DoD average worldwide price.

Currently (March 1988), DFA at McMurdo is 65 cents/gal., JP4 is 81 cents/gal., and Mogas is 73 cents/gal., all well below prevailing retail prices for many parts of the U.S. In the last three years, the McMurdo price for DFA has ranged from 65 cents to 82 cents, while JP4 has ranged from 70 cents to 81 cents.

For fuel at the South Pole, one rule-of-thumb is that 3 gal. of JP4 are consumed to deliver 1 gallon of fuel to the station from McMurdo. When operating costs for the aircraft and the directly applicable ground facilities are considered (see below), the fuel bought in McMurdo for less than \$1/gal. should increase its effective price to about \$8/gal.

Carriage of freight within Antarctica

Unless air drops can be used, all cargo delivered to inland sites is carried by LC-130 ski-wheel aircraft, either the LC-130R or the older LC-130F. The payload for the aircraft varies to

some extent with the model, it is lower for ski takeoffs than for wheel takeoffs, it varies with the flight distance (or fuel load), and it is affected by gross weight landing limits at some inland sites (including South Pole).

The direct distance from McMurdo to the South Pole is about 730 nautical miles, or about 840 statute miles. The one-way flying time is about 3 hr with zero wind (climb, 275 TAS, approach). All engines continue to run while the plane is on the ground at Pole, consuming more than 40% of the fuel used in normal flight (310 and 460 gal./hr, with and without low-speed idle feature). Minimum time for a round trip is about 7 hr, with typical round-trip time perhaps about 8 hr. Fuel consumption in level flight is about 660 gal./hr at fairly high altitude; consumption is higher when climb accounts for a significant part of the flight duration (770 gal./hr for flights to the DYE sites in Greenland), or when flights are at low altitude.

For flights from McMurdo to Pole, the newer planes are rated to lift about 13 tons on wheels and 11 tons on skis. The oldest planes can carry about 9.5 tons. Since it is not always convenient to make up loads to the limit of the aircraft capacity, and since passengers are usually carried, the average cargo load that is actually delivered is likely to be well below the limit. During the South Pole construction project from 1970 to 1973, a total of 1,097 tons was delivered on 166 flights, for an average cargo load of 6.6 tons. A typical load nowadays might be 8 tons.

All the LC-130 aircraft currently used in Antarctica are owned by NSF. They are operated by U.S. Navy crews.

Air freight costs in Antarctica

It is difficult to establish a true cost for carrying passengers and freight within Antarctica. NSF uses a rate of \$1,600/hr as the "incremental cost" to be charged against projects which use the LC-130. This appears to be a direct hourly operating cost, covering fuel, maintenance that is based on hours flown, crew costs, and perhaps some ground support costs. It does not cover the cost of ownership of the aircraft, which in a commercial operation would involve fixed costs (calendar costs) including insurance, registrations, financing, amortization, hangar/tiedown, ground staff,

and so forth. One factor that keeps the hourly rate low is the bargain price of fuel, which at present accounts for about \$600/hr, or almost 40% of the rate.

While fixed costs are difficult to estimate, they must be substantial. For example, in the absence of hull insurance, a self-insurance fund is required. If it is assumed that one aircraft is destroyed, or equivalent damage is accumulated, every 10 years, a set-aside of about \$3.5 million per year is currently needed to maintain the size of the fleet. Distributed over the fleet, this is equivalent to an annual assessment of \$0.5 million against each aircraft. Depending on the productive hours flown in Antarctica, this alone could represent a significant addition to the hourly rate.

The New York Air National Guard, which operates ski-wheel C-130 aircraft, uses a minimum rate of about \$1,300/hr for DoD missions. This is intended to cover only the cost of fuel and crew. When operating for agencies outside DoD, the rate is about \$2,500/hr. This covers fuel, crew and maintenance, but not "ownership costs" or "profit."

The true long-term operating cost for an LC-130 in Antarctica could be well over \$3000/hr.

To estimate the cost of freight from McMurdo to Pole, assume that an average of 8 tons is delivered by one flight, with 7 hours operating time charged against the aircraft at the NSF rate (\$11,200). This gives a freight cost of 70 cents/lb. This value is certainly too low, as it makes no provision for fixed costs and for freight handling at each end of the route. For rough estimates, it is more realistic to accept a higher figure, perhaps close to \$1/lb for deliveries from McMurdo to Pole.

The significance of the freight cost depends on the unit value of the cargo. For high-value items costing \$10/lb or more (e.g. electronics), the air freight from McMurdo to Pole adds only 10% or less. For equipment that costs around \$3/lb (e.g. heavy construction equipment), the air freight adds a third of the original value. For low-cost supplies that are less than \$1/lb at source (e.g. fuel), the air freight dominates the final cost on site.

Passenger costs are modest when people are carried in fully-loaded aircraft. Applying the rate of \$1/lb to the NSF allowance of 275 lb for each passenger (with hand baggage), the cost of a "space-available" round-trip from McMurdo to Pole is only \$275.

Conventional construction in the United States

To get some kind of reference for runway construction costs in Antarctica, comparisons can be made against costs for construction in the continental United States.

At U.S. locations where there are no special technical problems, where supply lines are short, and where there is price competition among contractors, prices fall into fairly well defined ranges. After the site has been acquired, approved, surveyed, excavated, drained, leveled and so forth, the probable cost of placing the base course and the surface paving currently (1988) ranges from \$2.68/ft² (7 in. asphalt concrete over 36 in. crushed bank run gravel) to \$4.48/ft² (15 in. Portland cement concrete over 24 in. crushed bank run gravel). Thus, for a 3,000,000-ft² runway, the cost of the base course and the paving is likely to be in the range \$8 million to \$13.5 million. In places where the site development costs are high (e.g. cut-and-fill in rolling terrain, or fill in shallow water), these prices could easily double, putting total runway cost into the range \$15 million to \$30 million for an area of 3,000,000 ft².

Rapid construction in remote areas is more expensive, especially if there are stringent restrictions on environmental disturbance. At the Killick well site in Alaska, a rock fill runway was built on the tundra in one summer season about eight years ago. The runway was 5,200 x 150 ft, and the fill was 14 ft deep at one end. The cost was about \$10 million, giving a unit cost of \$12.82/ft². At this rate, a 3,000,000-ft² runway would cost \$38.5 million.

Conventional construction near McMurdo station

At Marble Point, runway construction could be considered a conventional operation; no new technology is required. Permafrost problems seem minimal and, by Alaskan standards, easy to deal with. The site has no exceptionally severe topography, and materials for fill and paving can be produced on site.

If the project has a leisurely schedule, with four months of summer work per year spread over several years, costs should not be dramatically higher than the costs for comparable work in the U.S. Construction machines can be delivered directly to the site by ship in late summer. Fixed costs for equipment will add a large increment to hourly cost because the machines will be unproductive

for much of the year. Hourly costs for operators and for routine maintenance might be about 50% above U.S. costs. The machines may have residual value at the end of the project and they could be shipped back to the U.S. Blasting could actually be less expensive than in the U.S., as there is no danger of damage claims from third parties. A summer construction camp presents no special problems, since temporary buildings and supplies can be delivered directly by sea, and backup facilities are available 50 mi away at McMurdo station.

Past estimates for construction have varied widely, with a low of \$38.7 million, which is the same as the pro-rated cost for a 3,000,000-ft² runway according to costs at Killick, Alaska, as discussed above. Reports of past studies give the impression that high estimates for conventional construction may be due partly to a very cautious and conservative approach to possible permafrost problems. By contrast, the low estimates are for unconventional and unproven methods involving deep fills of massive ice. Some of the assumptions underlying these various estimates might be worth reconsideration by specialists who have long experience in arctic construction.

Without attempting detailed new estimates, it is suggested that an effort should be made to design a runway that can be built for a base cost of about \$50 million, excluding any other airport facilities.

With the volume of traffic that can be expected over the next decade, maintenance costs for a hard runway at Marble Point should be minimal.

Runways on annual sea ice at McMurdo

Costs for preparing and maintaining the annual sea-ice runway at McMurdo are not available, as the work is part of the general effort by the Navy Public Works department. Contractor estimates have not been made. Techniques are well developed and there is no significant requirement for the development of new technology.

The annual effort at the sea-ice runway is comparable to the maintenance effort at the Williams Field skiway, which costs about \$550,000, excluding fuel costs and amortization charges on equipment. The actual cost for the skiway is probably about \$600,000, including fuel and non-accountable services, but not including periodic relocation of the camp. In round numbers, the true annual cost of the sea-ice runway is probably at least \$0.5 million, although the accounting charges for

the Navy operation may well give the appearance of lower expense.

Runways on glacier ice near McMurdo

One of the major items needed for a runway on bare glacier ice is an efficient ice planer. The least expensive way to acquire a special planing machine is to design it around a suitable piece of existing equipment. One possibility is to use a laser-guided grader, or a ski-mounted land-plane, as the carrier vehicle, replacing the moldboard with a rotating drum. The drum could have an internal hydraulic motor, or it could be powered by a mechanical drive-train. Another possibility is to adapt a cold road planer, as used for cutting and recycling asphalt pavement. A self-propelled grader has the potential for high working speeds, but its traction is limited, even with chains. It might be more practical to convert it to a towed vehicle, using the installed engine to drive the cutter drum. An asphalt reclamation machine would require modification to give high crawl speeds, with laser control of drum height. To develop and acquire two identical machines, the cost might be about \$1 million. Operation of the machines would not cost much. With two machines operating and three changes of operator per day, a 3,000,000-ft² runway in a favorable location could probably be planed from the natural surface in two or three weeks, with a labor cost of about \$60,000. Repeat planing should go considerably faster. Fuel consumption for the initial planing operation might be about 8,500 gal., with a cost of \$5,500 at current fuel prices.

Costs for summer maintenance are more uncertain. Excavation of interceptor drains for surface meltwater might be needed, using a small trencher costing about \$150,000. A machine for picking up surface meltwater from the runway, by brushing, squeegee-ing and/or vacuuming, might also be needed. This could add another \$300,000 to equipment costs. To keep the surface albedo as high as possible, the planers could be used for light scarifying. The alternative of placing and spreading snow, say by trucks, snow blowers, graders and rollers, would be expensive. A mechanized system for pothole patching would be useful. This could be a heavy dump truck, carrying snow and fitted with a hydraulic compaction device.

To create and maintain a runway on glacier ice, the initial investment for developing and procuring special-purpose equipment might be about \$2

million. Operating costs for the initial construction (labor, maintenance, fuel) might be around \$0.25 million. Summer maintenance and on-site services might add another \$0.25 million. After the first year, the routine maintenance (excluding major repairs to equipment) might cost about \$0.5 million for the period October–March.

Maintenance of a road from McMurdo station to the runway creates an important ancillary cost. From mid-June to the end of November, a direct route across the sea ice should be feasible. This road would be about 9 statute miles long, and for most of its length the only required maintenance would be snow plowing. During initial preparation, some ice chipping on the shelf might be needed, and a transition ramp from the sea ice to the shelf would be required. Costs for this road should be minimal. From early December until June, ground traffic would have to follow a route via Pram Point and the ice shelf, a total distance of about 14 miles. The road would go via Pram Point and the transition area currently used for access to the skiway (which is very troublesome in late summer). It would then loop around the embayment to the south of Pram Point, and subsequently head south-west to the runway. This could cost about \$200,000 a year.

An alternative for passengers and light cargo would be a robust short-range air-cushion vehicle (strong construction, diesel engines). A machine of this type ought to be capable of direct travel from McMurdo station to the airfield at all seasons.

To summarize the cost estimates for a runway on glacier ice, the first-year cost for the runway itself might be about \$2.5 million, with an additional \$0.25 million for road maintenance. This gives a first-year cost around \$2.75 million. In subsequent years, the maintenance cost for the runway and the access road might be about \$0.75 million.

Rock fill over ice

It is difficult to estimate costs for a rock-fill runway on the ice shelf, since no details are available for either the source of the fill or the equipment that might be used. The minimum amount of fill that is needed is 222,000 yd³ and the minimum haul distance could be about 12 mi (assuming a runway location that has reasonable access to McMurdo station). A fleet of very large dump trucks might be an unreasonable demand for McMurdo.

Without going into details, it is hard to imagine that the fill could be gathered, transported, placed, and compacted for under \$20/yd³, even with the bargain price for fuel at McMurdo. At this rate, the basic runway would cost about \$4.5 million. Taking into account mobilization costs and the need for a haul road across rough ice, the runway cost could easily be twice this figure, say \$9 million.

If rigid foam insulation panels could be used, the required amount of fill might be reduced substantially, but the net cost might not be very much lower.

Snow runway with ice pavement at McMurdo

It seems quite possible that a snow runway comparable to those at Molodezhnaya and Novolazarevskaya could be built on the ice shelf near McMurdo station. The initial cost might be quite low, say about \$2 million, and the annual maintenance cost would be comparable to the maintenance cost for the present skiway, say about \$0.6 million. However, a runway of this type would not solve many problems, since it would probably be useable only as a skiway in mid-summer, and its bearing strength at other times might be marginal for the C-141 (see notes on aircraft characteristics). The only type of snow runway that can be justified at this stage is one with an iced pavement.

Costs for an ice-over-snow runway cannot yet be estimated with confidence, as the required technology has not been developed. As a practical matter, the technology must be simple and inexpensive. In essence, the annual snow accumulation has to be transformed into a layer of snow-ice, and the required transformation may have to be brought about after every period of significant snow accumulation. If some kind of technique that involves wetting and rolling can be developed, then the maintenance cost might be of the order of \$0.8 to \$1.0 million. This would make the ice-over-snow runway competitive with the present arrangement.

Construction at South Pole

Construction possibilities at the South Pole are severely limited, since snow is the only material that is available at, or near, the site. The import of bulk construction materials, such as gravel or concrete, is completely out of the question. Construction options are also limited by the fact that

the site is an area of net snow accumulation, which means that fixed objects are eventually buried. The construction season is short—about three months.

Apart from snow, all materials and fuels have to be flown in, at a cost of about \$1/lb.

The work force has to be flown in and housed on site. Workers at Pole are likely to travel from the U.S., at a round-trip transportation cost of about \$3,000 per head. Additional costs for delivering a worker to the South Pole include pay and per diem en route (perhaps one week each way), medical examinations, and administrative costs for the travel arrangements. These costs could amount to another \$2,000, giving a total cost of about \$5,000 to get each worker to and from Pole each season.

Living costs on site vary according to the arrangements. At present, there is a surface camp that could probably be used and expanded during a new construction project. The main station provides backup facilities, including medical facilities and a maintenance garage for heavy machines. If it is assumed that existing surface facilities can be used, together with some new units, the living cost for a worker might be about \$200/day, which is not much more than camp costs for remote sites in Alaska.

Construction work at Pole is likely to go on seven days a week, with extended shifts every day. Allowing for overtime rates, differentials for the location, reduced productivity during overtime, and reduced productivity because of the environment, the effective man-day cost might be about double the U.S. basic rate. Including benefits, overhead and profit, a contractor's equipment operator might be charged at about \$500/day.

Until a runway construction technique is developed for South Pole conditions, cost estimates have to be based on speculation about the construction procedure. For present purposes, assume that a base course will be laid by specially designed rotary processing machines, and that the surface will be paved by a combination of water infiltration and heavy rolling. The latter reflects a degree of wishful thinking, as it is a simple procedure that could be repeated periodically to compensate for snow accumulation.

The machines for the base course might cost about \$0.8 million for two, including development and transport to the site. With two machines, the base course could be processed in 15 days, but a

more realistic estimate would be three weeks. To propel the machines, assume winch and anchor systems costing about \$0.2 million for two. This makes the base course machinery \$1 million. To run this equipment, assume six machine operators per day, assisted by six anchor setters and three maintenance mechanics. This is 15 people working for 21 days. Taking equipment operator rates at double the U.S. basic rate and adding overhead, profit and living costs, the labor cost for the operation is about \$220,000.

The site would need grading before the base course processing, and possibly again afterwards. The graders could be towed devices similar to the present land planes, but with laser-guided, servo-controlled blades. For two of these, we estimate \$0.2 million. They could be towed by two crawler tractors costing about \$0.4 million for two, complete with blades and winches. These tractors would have to be transported disassembled, since the total weight of each will be about 23 ton.

The same crew that runs the base course processors could work on the grading, which would use two grader operators, two tractor drivers, and two laser setters at any given time, with three shifts per day (18 people). The grading work could be done in a few days. Allowing four days for grading, this stage of the work would have total labor costs (including living costs, overhead, profit) of about \$50,000.

Fuel consumption for the base course operation, including the grading, might be about 0.06 gal. per hp-hour. The base course processors might have about 250 hp each, the tractors about 200 hp each. Various auxiliary power plants might total about 60 hp. Total fuel consumption for the base course operation might be about 15,000 gal. At a fuel cost of \$8/gal., this is a total cost of \$0.12 million.

For the paving, assume that somehow or other a wet snow surface is produced, either by infiltration or by mixing, with the water and fuel quantities calculated earlier (82,000 gal., costing \$0.66 million). A special machine is needed to dispense the water, and a water production system is needed. In the absence of any technical details for this equipment, estimate \$0.8 million, delivered to the site. Assume further that the wetting machine is followed by a heavy rubber-tire roller, say a ballasted 100-ton roller, weighing 30 tons dry, and towed by one of the tractors. The roller might cost about \$0.15 million, with another \$50,000 in shipping costs, for a total of \$0.2 mil-

lion. The required working speeds for wetting and rolling are not really compatible, but for cost estimates it will be assumed that the two operations are somehow coordinated, and completed in 14 days. Assume that the equipment is run by four operators, with three changes per day, i.e. a total of 12. The labor cost is then about \$118,000. Fuel for the tow vehicles and the drive engine of the wetting machine might be about 8,000 gal., or \$64,000.

If we assume that the entire operation can be carried out by a work force of 25 (excluding kitchen/housekeeping staff), and that this crew is on site for 60 days, the cost of labor (including living costs and travel to the site) is about \$1.2 million. The equipment cost (including delivery) is about \$2.6 million. This makes no allowance for development costs or for salvage value. The total fuel cost for melting snow and running the vehicles is about \$0.9 million. Thus, according to these assumptions, we are looking at a project cost of about \$5 million.

Annual maintenance will be required in order to convert the year's snow accumulation into pavement. If the runway project is to be viable, there must be a simple procedure for converting the annual 7-in. snow layer to snow-ice that is denser than 0.6 Mg/m^3 . Until such a procedure is developed, we cannot estimate the annual maintenance cost. However, we cannot expect this annual operation to cost under \$100,000, and it could be considerably more.

Blue-ice runways at inland locations

Before a blue-ice runway can be developed, a suitable site has to be discovered. The first step is to use maps, air photos and, if possible, satellite images. This should be fairly inexpensive, say around \$30,000 for location of several potential airfield sites. The next step is air reconnaissance and ground survey, which is more expensive. Using an LC-130 based at McMurdo, the flight-time charges according to the NSF rate (\$1,600/hr) would be at least \$50,000, unless some missions are integrated into routine inland supply flights. If potential sites can be reconnoitered during return flights from Pole early in the season, the effective cost would be low, perhaps about \$15,000. Using a four-man party for the ground surveys (say two specialists, two contractor personnel), the labor cost could amount to about \$50,000. Field equipment for the survey party could probably be supplied from the Berg Field Center (two snowmobiles would be needed, plus field shelters, radio, food, cooking gear, and so forth). To develop a blue-ice airfield, the basic requirement is for markers, field shelters, emergency fuel supply, some kind of wind fence, and a small snow plow for clearing isolated patches of sastrugi. This might amount to \$200,000. To establish a blue-ice runway at a suitable inland site, the total cost might be around \$350,000.

IX. CONCLUSIONS AND RECOMMENDATIONS

Conclusions

A capability for making wider use of standard wheeled aircraft in Antarctic operations is clearly desirable. However, the quest for all-season wheel runways in very close proximity to McMurdo station and South Pole station is less easy to justify, since both sites are ill-suited for construction of permanent hard-surface runways.

At McMurdo, the best choice for the *long term* is the hard choice: Marble Point. The consideration that disqualified this proposal in the past was the perceived need for total relocation of McMurdo station, at very high cost. An alternative to complete relocation is relocation of major air operations, port facilities and bulk storage, while retaining the present station as a research facility. Marble Point would become the port-of-entry, logistics center, and transit camp. McMurdo station would house and support scientists engaged in local research. High-speed communication could be provided by air-cushion vehicles over most routes and at almost any time of the year.

For the *short term*, development of all-season wheel operations at McMurdo is technically feasible at fairly low cost by building a runway on glacier ice. The penalty is long travel distance to and from the airfield, and the high cost of maintaining a summer road. Again, consideration of air-cushion vehicles is indicated.

A rock-fill runway on the ice shelf would be much more expensive initially than an ice runway in the same location, and the problem of long travel distance remains.

The only other possibility for all-season wheel operations at McMurdo is development of new technology for making snow runways with iced pavements at, or near, the location of the present skiway. The required development work would take several years, and a successful outcome cannot be guaranteed.

At South Pole, a wheel runway for heavy aircraft cannot be built without the development of new technology. Compaction of dry snow alone is unlikely to produce a safe pavement. The runway requires a base course of compacted snow, with a hard pavement produced by high pressure, fine-grinding, heating, water infiltration, or chemical modification. Elaborate technical solutions are inadmissible because of repeated requirements for the conversion of new snow into hard pavement. To be practical, the paving method should

be simple, rapid and economical. Landing mats or other manufactured runway surfaces are not feasible for South Pole.

Given the technical difficulty of making a wheel runway at the South Pole, the perceived requirement for such a runway deserves careful scrutiny. The main benefit is more economical delivery of supplies, but as long as the research group at Pole is small, the extent of the real benefit is quite limited. A wheel runway at Pole is likely to attract traffic from other nations or from commercial interests.

Finally, a single isolated runway in the center of Antarctica is not very appealing. Wheeled aircraft operating in the interior really ought to be provided with alternates to which they can divert in case of difficulties.

Support for South Pole and other inland stations would be facilitated by inexpensive, all-season, wheel runways in the interior. Blue-ice areas provide expedient runways at very low cost. Two such airfield sites in the Pensacola Mountains were surveyed for NSF in 1974. A blue-ice runway in the Patriot Hills is now in commercial use. A blue-ice airfield in the southern Queen Maud Mountains, say at the head of the Scott Glacier or the Reedy Glacier, would be valuable. Heavy freight and fuel could be delivered in wheeled aircraft to a satellite airfield on blue ice, conceivably within 250 nautical miles of the Pole. Onward transport could be by sled train. Passengers could be carried direct from New Zealand or South America to the interior, with onward travel by small ski-wheel aircraft, such as the Twin Otter.

Given the very low cost of blue-ice airfields, it would seem prudent for NSF to firmly establish right of access to some of these areas. A well-distributed set of blue ice airfields could improve the safety margins for wheeled aircraft operating in the interior. Flights could divert to one of these places in the event of weather problems or mechanical difficulties. The need for extreme-range flights could be reduced by placing fuel at selected blue-ice airfields.

Permanence and easy maintenance are highly desirable characteristics for Antarctic runways. Airfields on snow-free rock or on snow-free glacier ice are attractive in this respect.

Table IX-1 gives a subjective summary of conclusions concerning all runway concepts that were considered in this study.

TABLE IX-1

Type of Runway	Assumed pattern of use	Requirement for special skills and experience by ground personnel and/or aircraft	Maintenance cost for assumed pattern of use	Degree of permanence	Value of completed asset			Acquisition costs			Technical risk in pursuing this development
					Adaptability to routine civil aviation operations	All season availability	Operational hazard	Concept development cost	Construction cost	Approximate amortization period for construction cost	
Hard surface on rock or soil	Regular use. Full-time availability at all seasons. Frequent flights in summer.	No	Moderate	High	High	Low	Low	High	High	Indefinite (> 15 yr)	Low
First-year sea-ice	Regular use and full-time availability for 3 months (Oct-Dec).	Yes	Moderate	Low	Moderate	Low	Moderate	Low	Low	1 yr	Low
Multi-year sea ice	Regular use and full-time availability for 3 months (Oct-Dec). Restricted operations Jan-Feb. Occasional winter use.	Yes	Moderate to high	Low	Moderate to low	Moderate to low	Moderate	Moderate to low	Moderate to low	~ 2 yr	Low
Blue ice (inland locations)	Regular use in summer. As required at other times	Yes	Low	High	Moderate	High	Moderate	Low	Low	Indefinite (> 15 yr)	Low
Glacier ice (coastal ablation areas)	Regular use. Full-time availability at all seasons. Frequent flights in summer.	Yes	Moderate to high	Moderate	Moderate to high	Moderate to high	Moderate	Moderate to low	Moderate to low	~ 7 yr	Low
Rock/gravel over glacier ice (low ablation rate)	Regular use. Full-time availability at all seasons. Frequent flights in summer.	Marginal	Moderate to low	Moderate to high	High	High	Moderate to low	High	High	~ 10 yr	Moderate
Processed snow with ice pavement (coastal accumulation areas)	Regular use. Full-time availability at all seasons. Frequent flights in summer.	Yes	High	Low	Moderate	Low	Moderate	Moderate	Moderate	~ 3 yr	High
Processed snow with ice pavement (high altitude (inland sites))	Regular use in summer. As required at other times.	Yes	High	Low	Moderate	Moderate	Moderate	High	High	~ 3-5 yr	High
Manufactured mats over compacted snow (inland sites)	Regular use in summer. As required at other times.	Yes	High	Low	Moderate to low	Moderate	Moderate to high	High	High	~ 3-5 yr	Moderate

Recommendations

An examination of the overall situation in Antarctic aviation should be made by NSF, taking into account: (a) program projections for the next two decades, (b) aircraft developments and the economics of air operations, (c) evolving aviation activities by other nations. This would provide a framework for important decisions on the development of new airfields. Until such guidance is available, the following recommendations are offered.

- 1) Making the reasonable assumption that a runway will eventually be built at Marble Point, begin site development at a pace that is sustainable within the present budget. For FY89, commission an expert in arctic construction to make a low-cost (= \$25,000) review of Marble Point runway design and obtain civilian and Navy estimates for low-intensity cut-and-fill operations at the site.
- 2) Noting that blue-ice runways are by far the least expensive wheel runways in Antarctica, locate, survey and test one or more blue-ice airfields, leaving tangible evidence of occupation. For FY89, commission experts in Antarctic glaciology and polar aviation to study air photos of selected areas (= \$12,000) and, if possible, follow up with air reconnaissance and preliminary survey (flight requirements to be integrated with inland support operations).
- 3) If all-season wheel operations are required at McMurdo soon, make a detailed review of the proposed glacier-ice runway in order to decide whether the site is acceptable. In the case of an affirmative decision, work during FY89 on: (a) site survey, (b) designs and construction proposals for ice planers, (c) summer maintenance schemes.
- 4) If the development of hard-surface snow runways at McMurdo or Pole is judged to be necessary, initiate a systematic R&D program directed to the production of snow-ice pavements. For FY89, make small-scale field studies at McMurdo and Pole, looking at: (a) compaction and sintering characteristics of very finely ground snow, (b) solar warming of dusted surfaces, (c) water infiltration into compacted snow, (d) effects of chemical additives at low concentration, (e) compaction of snow that is warmed and/or wetted. Supplement field investigations by laboratory studies. Consider use of ANS personnel for field studies.
- 5) Noting that runway options are adversely affected by ground transport inadequacy, run trials with a heavy-lift ACV such as the LCAC (U.S. Navy) and/or with a lighter ACV such as the LACV (U.S. Army).

APPENDIX A

Site Information for Marble Point (from "Environmental Assessment for Proposed Long Range Development of the Marble Point Area at Antarctica," for NSF by PACDIV, NAVFACENGCOM, 15 February 1985).

The Proposed Action

1. Description of Present Marble Point

Marble Point is located about 50 miles northwest of McMurdo Station (Ross Island). Marble Point is a natural gateway to the Taylor, Wright and Victoria Dry Valleys at the terminus of the Wilson-Piedmont Glacier, and is relatively barren of plant and animal life. This rocky promontory, with elevations of 200-300 feet, is overlain by 2-3 feet of gravelly sand with permafrost to depth of about 10 feet. It remains essentially free of snow year-round and thus presents possibilities for a year-round hard surface runway. The USARP has maintained a helicopter refueling station and emergency hut at this location in the past to support the extensive research effort in the Dry Valleys.

Marble Point area contemplated for this development is essentially part of a series of raised marine beaches in front of the Wilson-Piedmont Glacier. This glacier has been retreating from the coast. When the ice of the glacier extended farther seaward than it does today, these beaches were pressed down, like all the ground underlying the ice. Then, since the ice shrank back, the beaches have been slowly rising as an isostatic readjustment to the removal of the ice load (Figure A-1).

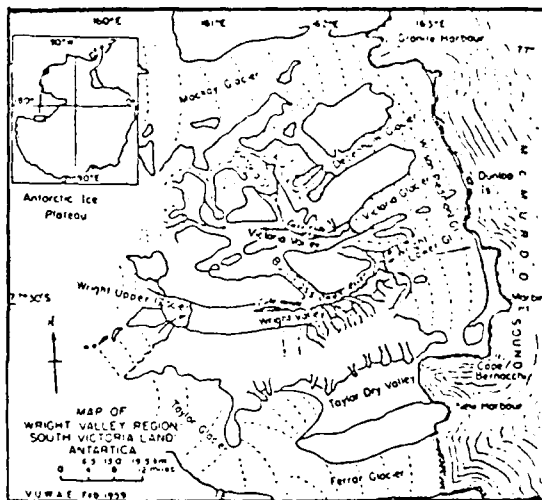

Map of the Wright Valley region, Victoria Land, Antarctica.

Figure A-1

2. Description of the Proposed Improvements

The projected need and highly desirable operational advantages of having an all weather runway in the Antarctic stimulated the development of a plan for a new station at Marble Point. The Marble Point site, although it also had certain limitations, presented the most advantageous site. The area was fully investigated to validate the preliminary site data which had been developed under earlier ground surveys carried out jointly by the U.S. Navy and civilian contractors.

The plan for the development of a station at Marble Point is shown in Figure A-2. The station includes all necessary facilities to support a population of 806 people at a single consolidated site which is centrally located between a 10,000 foot permanent runway and a deep-water port capable of accommodating both cargo and tanker vessels with minimal ice breaker

support. This concept of a consolidated living area results in a much more efficient operational mode than that now utilized at McMurdo Station. Because of spatial constraints, McMurdo requires a separate support complex at the skiway and a second temporary support complex on the sea ice during the ice runway operations. The result of this consolidation is to minimize the number of support personnel. Ultimately, this will result in an increase of scientific projects possible, assuming a constant level of program funding.

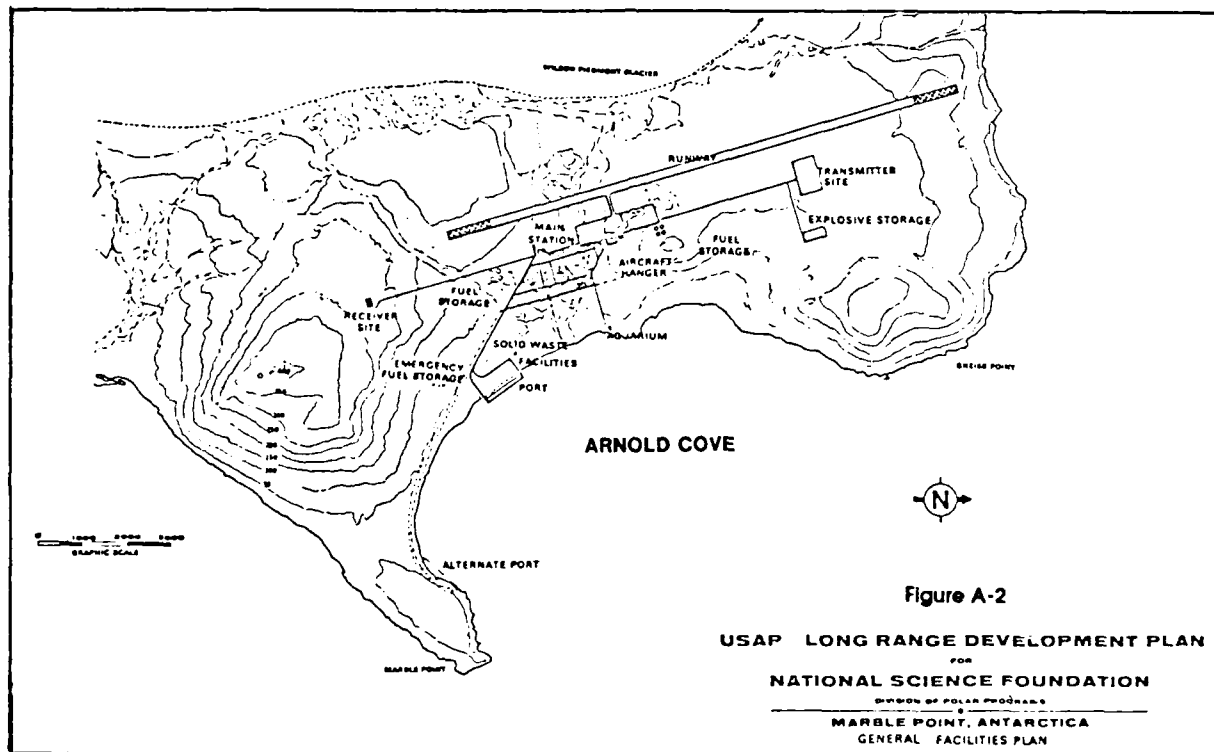

The station was designed to take advantage of the natural topography of the Marble Point area. The land use patterns of the station and the inherent requirements of the varying functions resulted in designated groupings of housing, service and support elements, administrative elements, utility systems and other functions. These groupings were then collated, based on operational interrelationships, with the focal point being the primary scientific and administrative building. Housing is grouped and located at the south end of the station and is stepped downhill to afford lounge areas and the maximum number of rooms a view of McMurdo Sound. This grouping also eases utilidor construction since the housing units are a major consumer of power and water and a generator of liquid and solid waste.

The construction of a completely new station at Marble Point will cost approximately \$300,000,000 (1978 estimate), spread over a six-year period, five of which include actual onsite construction. This development period was selected in order to:

- . Minimize the time during which two major support bases (McMurdo and Marble Point) would be in operation concurrently.
- . Initiate scientific operations at the Marble Point Station at the earliest possible date.
- . Optimize the overall cost by mobilizing a construction force for the fewest years possible.
- . Eliminate any construction which is not permanent.

EXISTING ENVIRONMENT AT THE PROPOSED SITE

Physiography

Marble Point is located at a latitude of 77° 25'S and a longitude of 163° 40'E. It is approximately 2,100 nautical miles south of Christchurch, New Zealand, and 826 nautical miles from the South Pole; and it is approximately 50 miles northwest of the present primary support base at McMurdo Station. Its general location on the continent is shown in Figure A-3.

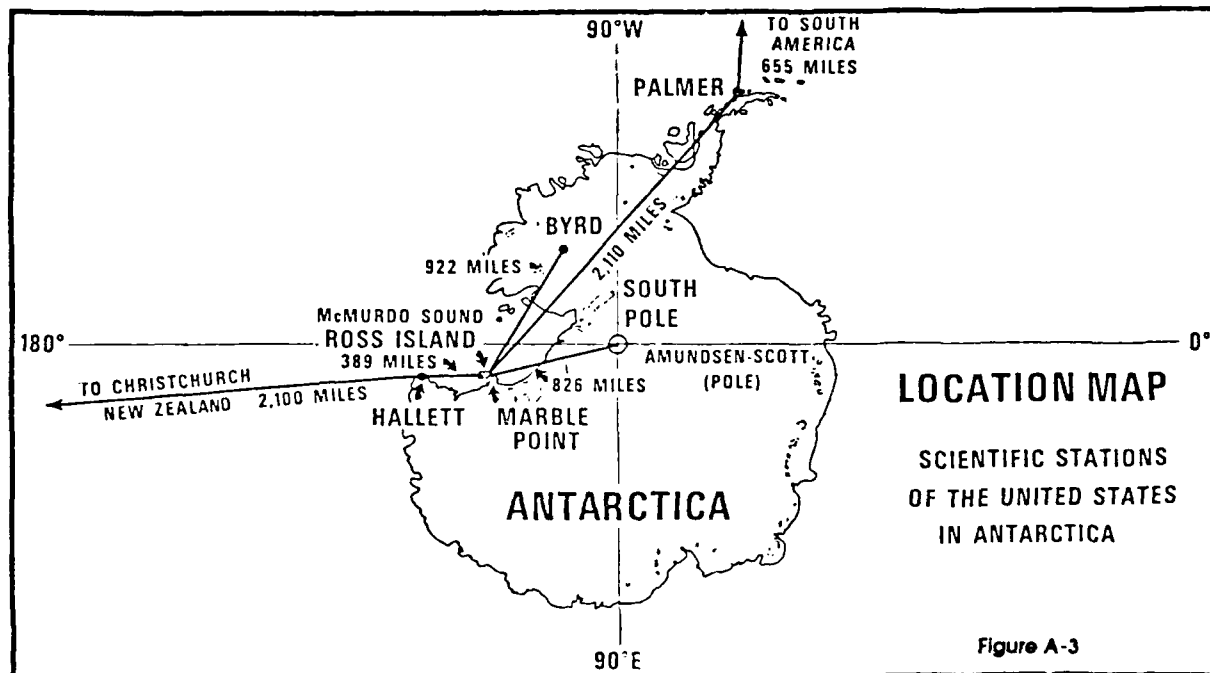

Figure A-3

The area experiences a wide range of climatic conditions ranging from harsh in the austral winter to relative mild during the austral summer, but average temperatures are usually slightly warmer than at McMurdo Station. Temperatures recorded show an average range of -7° to -1°C (19° to 30°F) during the austral summer. Winter temperatures have been recorded as low as -35°C (-32°F). Average winter temperatures are anticipated to be basically the same as or slightly warmer than those recorded at McMurdo, based on comparisons of available temperature data.

Precipitation occurs only as snowfall, but too little data is available to establish an annual average. Records for the summer period show that trace snow falls approximately 3 to 13 percent of the time. Very little snow cover -- mainly drifts on the lee side of obstacles -- has been found by groups visiting in October, which suggests that snowfall is minimal during the winter period, allowing the majority of the area to blow clear. At the end of the summer periods very little snow cover remained.

The prevailing wind is from the south at an average velocity of 5 to 8 knots with gusts up to 24 knots during the summer season. Higher winds are anticipated during storms, but comprehensive year-round wind data for an extended period are not available.

The area selected is located on the edge of the continent and bounded on the north by Gneiss Point and on the south by Marble Point, a distance of approximately 4 miles. The western boundary, the face of the Wilson-Piedmont Glacier, varies from one to three miles from the sea edge due to the configuration of Arnold Cove. The general area, including Marble Point's relation to McMurdo, is shown in Figure A-4.

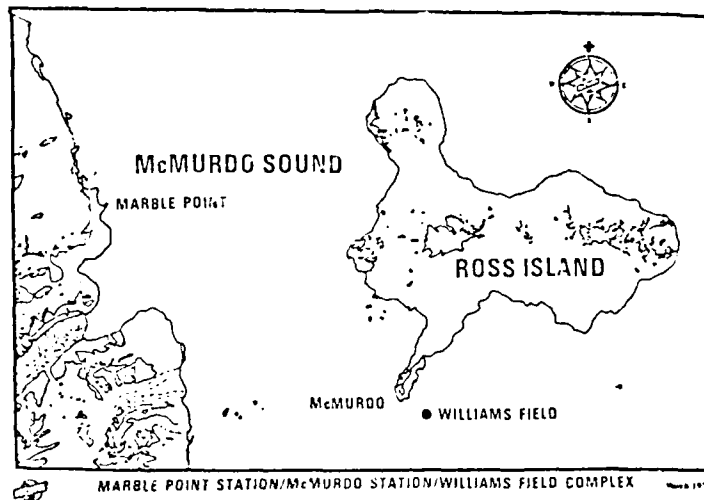

Figure A-4

The proposed site gradually slopes from the glacier's face to the edge of the sea, with small rolling hills protruding throughout. Major hills are located inland from both Gneiss Point (Reigel Hill with peak elevation of 292 feet) and Marble Point (Gino Hill with peak elevation of 408 feet).

The surface is generally covered with glacial till, with rock outcrops occurring in many locations. The rock outcrops are composed of gneiss, schists, solerite, marble, and granite. Permafrost underlies the entire area, with subsurface investigation revealing an active layer approximately 22 inches in depth. A number of glacial melt streams occur in the area, and two major fresh water ponds are located near the face of the glacier.

Hydrographic soundings indicate that the Arnold Cove bottom gradually slopes out, reaching a depth of 30 feet approximately 250 feet from the shoreline. Hydrographic information relative to the area adjacent to the proposed port area was obtained from the U.S. Navy records.

The only existing facilities in the project area are two Jamesway structures used as a construction camp, a test gravel landing strip constructed during the 1958 field work, and a helicopter fueling facility used during the austral summer consisting of a small wanigan, two fuel bladders, and a pump and hose system. Three new small plywood buildings were constructed in 1984. None of these facilities presents any constraints to development of the area.

In austral summer 1984, a small camp manned by 8 persons was established at Marble Point to mark with flags the approximate boundaries of the 10,000 foot runway and related structures. Minor expansion of existing facilities, limited to the erection of prefabricated builds were undertaken as the first increment to indicate the intent of the United States to occupy and develop the area as a major U.S. station at some future time.

Flora and Fauna

Except for some lichens and algae and migratory birds which use Davis Lake for bathing and drinking, Marble Point area has a paucity of flora and fauna. Penguins, seals, and other mammals do not normally inhabit this area. There are no rookeries present.

Archaeological/Historical Landmarks

There are no known archaeological or historical areas of significance in the Marble Point area.

ENVIRONMENTAL CONSEQUENCES

Direct Effects and Their Significance

Construction of the proposed Marble Point Station is certain to have some impact on the environment for it introduces human occupancy, use and activities in an area which is now relatively undisturbed. A helicopter refueling station and an emergency hut were maintained there in the past to support USARP research efforts in the Dry Valleys. However, since Marble Point area contains little or no flora or fauna, and is not known to have any areas of historical or archaeological significance, the impacts will be changes in the topography due to construction of the runway and station facilities, increase noise levels, and changes in air and water qualities.

Airfield Construction

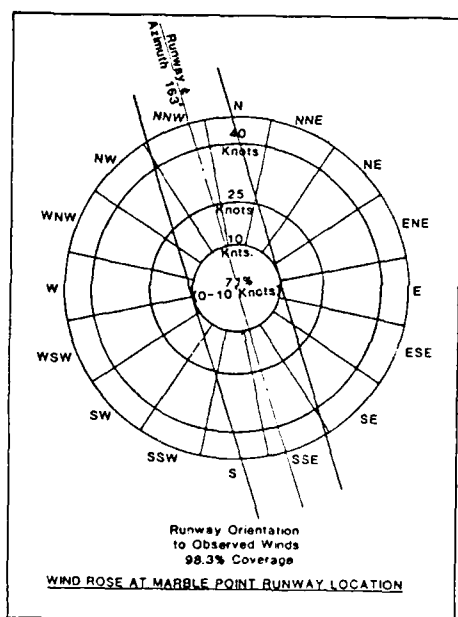

Figure A-5

The general topography of the Victoria Land Coast in the Antarctic is characterized by high mountain ranges to the west and the Ross Sea to the east. This land pattern prevails in the vicinity of the site with mountainous terrain and glaciers to the west and McMurdo Sound to the east. Fortunately, the prevailing wind moves parallel with the coastline and the general contour of the area. Wind observations taken at the site, and the orientation of snow fields, snow drifts, silt deposits and ventifacts indicate that the prevailing wind is from the south to southeast (Figure A-5).

Three possible locations of the 10,000 foot runway were studied in the general area encompassed by Marble Point on the south, Gneiss Point on the north, McMurdo Sound on the east, and the Wilson-Piedmont Glacier on the west. Area south

of Marble Point to Cape Bernacchi was not studied because the general slope of the land was too steep for runway development.

The alignment chosen lay approximately midway between the sea and the glacier on a true azimuth of 165 degrees (see Figure A-2). Of the three alignments studied, it offered the most level terrain, missed hills, and had favorable approach zones which was completely clear from the north and lay closely over the terrain between Cape Bernacchi and Hogback Mountain from the south. The mid-length elevation of 200 feet gave it sufficient elevation to be unobstructed by many of the local hills. The levelness of the terrain would make initial development possible with a minimum of earthwork. The northern end would require a large fill in the overrun area and the southern

end would require a fill to maintain the proper sight distance on the runway and high fill across Surko Creek. These serve to minimize the degree of obstruction caused by the hills that lie on either side of the extended centerline. This alignment is considered to be the best possible in the general area and best satisfies all the current criteria contained in the U.S. Navy's Planning Standards for Air Station Facilities.

The terrain selected for the runway was well suited for the development of the runway by stages. The initial 5,000 feet by 200 feet runway, with 150 foot shoulders, would be sited on the most level terrain. Extension to 8,000 feet can be achieved by extending the initial development both north and south, and providing for the full 1,000 foot overruns and a 2,000 foot crash strip on the upwind (south) end.

The elevation and grade of the runway were determined with three factors considered, a) approach zone excavation, b) runway and overrun area fill and c) drainage and water supply. The area near the midpoint of the runway and the selection of its elevation and grade were critical in reducing the volume of earthwork required for the initial 5,000 foot runway. To reduce the elevation at the south end requires that either the north end be raised or additional cut be made in the initial section, both undesirable alternatives. This would also increase the degree of approach zone hazard offered by McTigue and Gino Hills.

The runway will lie across the large melt stream of Surko Creek. Its flow could be passed under the runway fill at several possible locations by a large culvert, albeit difficult to install culverts properly under permafrost conditions. The runway could serve as a dam at the Davis Lake area, and the resulting lake, when full, would serve as a water supply for the base. From a study of the excavation and fill quantities to be required for the runway construction, it may be practical and economical to remove a portion of either or both McTigue Hill and Gino Hill in conjunction with the construction of the high runway fill and dam across Surko Creek.

Another consideration for the limiting of excavation is the difficulties to be encountered in permafrost work, especially in runway sections to be paved. Tests show that ice bearing permafrost may be present in the top 3 to 6 feet. Seismic soundings confirmed by test pits and drill holes show a high bedrock elevation.

The design of the runway was based on consideration of minimum excavation in permafrost and on relative elevations needed to achieve favorable drainage, water supply, sight distances, approach zones, and proper alignment in relation to prevailing winds. Material from permafrost zone are not ideal for runway construction because of the difficulty of excavation and the thawing of the material which affects its structural strength as fill. Depth of thaw under a black paved runway surface would be greatly accelerated because of absorption of the sun's heat. Placement of a layer of rigid insulation between the runway pavement and fill embankment may be required to minimize thawing of the fill.

The runway should have non-frost susceptible (NFS) fill as permafrost insulation. Although such NFS fill is available, because of the magnitude of volume and hauling requirements involved, the cost of constructing the runway is substantial. The usual permafrost construction techniques incorporates ice into the field of construction material. By preserving and confining the ice inclusions in frozen soils, permafrost construction of fills is possible. If ice is kept below freezing and confined so that loads will not cause crushing or plastic flow, there is no bar to its use as a construction material.

At Marble Point, an alternative method of using ice in lieu of earth and rock fill for construction of the runway was considered. Water could be frozen in the section of runway fill at Surko Creek, then the ice covered with an insulating layer, thus benefiting from more economical construction costs. At Surko Creek, water and insulating fill not susceptible to frost are available and the pattern of ground temperatures is such that the ice fill core could be kept frozen. The insulating fill will be of sufficient depth to prevent any thawing from taking place in the ice fill.

The basic method of constructing ice fill is to build low earthen dams along the toe of the fill slopes and fill the resulting basin with water from the summer melt streams or lakes. The water depth should not exceed 10 feet so that it could be completely frozen to the bottom in one winter season. The following year it would be necessary to put an insulating blanket of earth on the ice to save it during the summer and the process of dam building, ice filling, and insulating repeated until the total height of fill is attained.

This method will take several season and employ a rather large amount of earth for construction of the dams and sandwich insulation. Other variations in the procedure of constructing ice fill can be explored, but the ultimate use of ice fill for the construction of runway is still dependent upon further investigation and study.

Earlier cost estimates for the two methods of constructing the 10,000 foot runway at Marble Point shows a substantial cost savings if the ice fill method was use.

The first method, using earth fill as the basic construction material, had a construction cost estimate of \$223.4 million (1979 cost), but this estimate is subject to change with development of more cost-effective equipment for scraping and hauling frozen earth fill material. The second method, using ice fill as the basic construction material, was estimated at \$38.7 million (1979 cost). Use of ice as a fill is not a tested and proven method, and must undergo extensive field evaluation before such a construction project is initiated.

Costs of the two construction methods considered are order-of-magnitude estimates. Detailed engineering identifying factors such as haul distances, equipment, exact fill requirements, labor rates, ice insulation requirements, ice creep characteristic, and availability of rigid insulation for use under runway pavement must be considered as part of the final design. The cost of all these items and many more, will change with time and must be evaluated in the same time frame as construction.

A permanent runway of 10,000 feet with all-weather navigational aids would allow continuous wheeled operations into Marble Point. C-141, C-130 and commercial aircrafts such as DC-10s and 727s could operate from such a facility. This would allow all intercontinental flights to be handled without utilizing ski-equipped C-130 aircraft. With appropriate hangar space, the need for maintenance flights to New Zealand would be significantly reduced if not eliminated; nearly all maintenance could be done on-continent. This would increase the on-continent time available by 16 percent. The ability to operate on wheels when departing for inland stations increases the possible payload approximately 6 to 12 percent, which translates into additional available aircraft time for other uses. In total, about 24 percent more usable flight time results from the construction of a permanent runway with no change in aircraft assets. This time, directly applied to field party support, will double the science output in Antarctica.

In addition, strictly wheeled aircraft could be used for operations that start and end at Marble Point without intermediary stops. Examples are ice sensing and air sampling flights. This would again release ski-equipped planes for maximum use.

The introduction of a permanent runway could have major impact on the U.S. National Program in Antarctica including the scientific program. It would allow expansion of the summer inland research program, reduce the direct cost of resupply existing stations, open up the possibility of year-round operations on an expanded scale, and add a safety factor never before available. It would give the U.S. an increased and visible presence in the Antarctic, and would undoubtedly be beneficial to the entire international community.

The majority of landings will be made to the south, utilizing a standard left hand pattern which will pass over the sea or sea ice to the northeast. A majority of takeoffs will be to the south, with climb-outs and missed approaches bearing slightly to the left or east to avoid Hogback Mountain and Hjorth Hill. During periods of low velocity, north wind or cross wind, takeoff to the north would be considered.

The area east of the runway taxiway system was selected for development of the mass parking apron. An area 900 feet by 1,800 feet is sufficient for the ultimate development, with space for hangar and flight line facilities available along the back edge and ends of the apron. The initial runway development includes a connecting taxiway and a small portion of the apron, so as to clear aircrafts from the runway area and provide nominal parking and servicing areas. The initial apron is sited on terrain requiring minimal earthwork and in an area where initial hangar construction is considered favorable.

APPENDIX B

Impact Compaction Machines for Snow Roads and Runways

Introduction

Snow on the ice caps of Antarctica and Greenland is, for most practical purposes, of infinite depth. It cannot be compacted effectively by conventional rollers or sleds, mainly because there is insufficient static reaction (weight) to develop adequate pressure over the necessarily large bearing area (high pressure on small area simply leads to indentation without compaction). Neither can the snow be compacted effectively by vi-

bratory tampers, since the amplitude of the vibrating mass is again insufficient to provide enough stress, or energy, over a large bearing area. These difficulties can be overcome by impacting the snow vertically with an open box, applying high blow-energy at low frequency. This note outlines two variants of a machine that could do the job. One version uses a drop-weight at extremely low frequency. The other version uses a low-frequency piling hammer to drive the box.

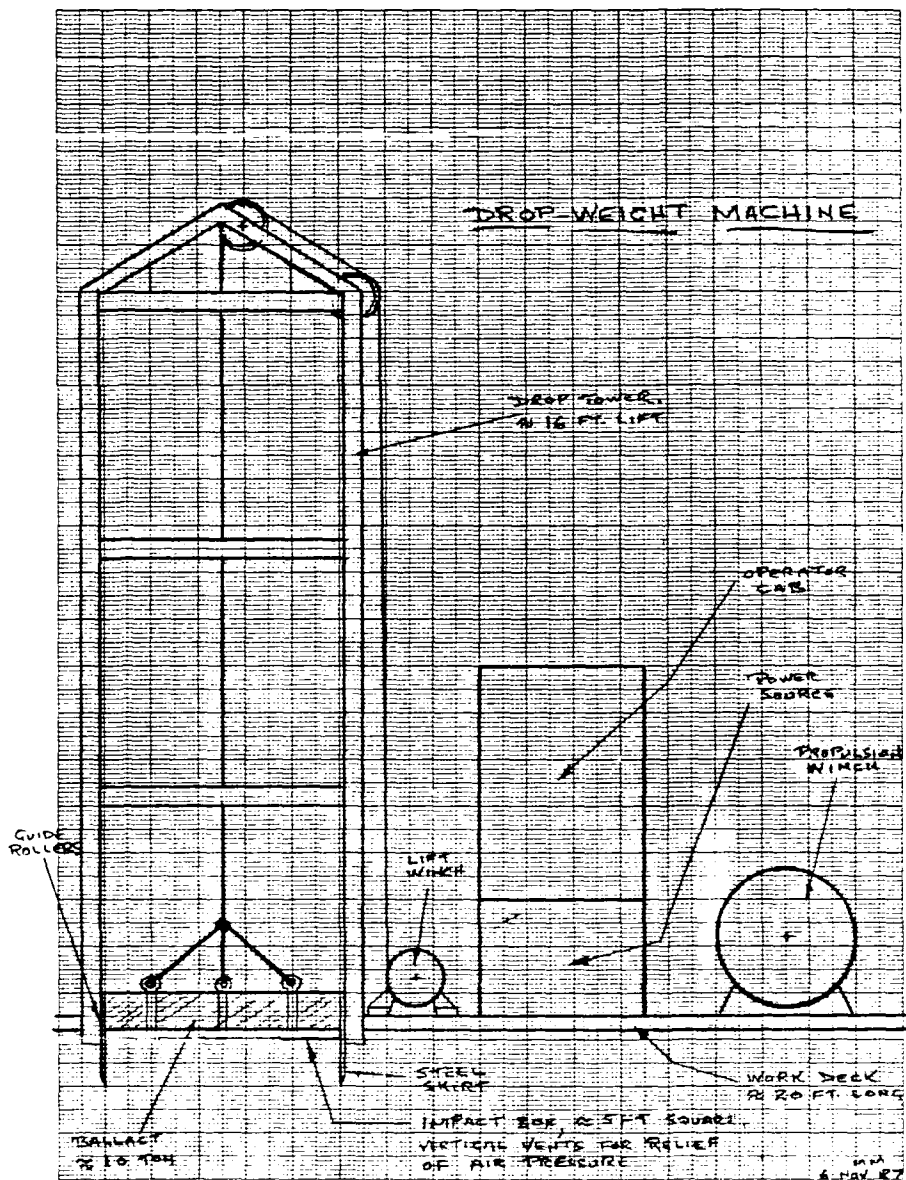

Figure B-1.

General description of the machine

The key element of each machine is an open box that is driven vertically into the snow. For a given amount of energy per unit area, the depth of compaction is directly proportional to the width of the box in snow that is homogeneous. For purposes of illustration, consider a box that is 5 ft (1.5 m) square in the horizontal plane, with vertical sides (skirts) that are about 1 ft (0.3 m) deep. The 5-ft-square horizontal plate is the impact surface. It is vented to allow air to escape from the pores of the snow during rapid compaction.

In the drop-weight version of the machine, ballast weight is carried on top of the box, and the box plus its ballast drops under gravity inside a guide frame. The drop height is approximately 16 ft (\approx 5 m). The total weight that is dropped may be in the range 10 to 15 tons. The falling mass is aimed and guided by a frame, inside which the mass is lightly restrained in the horizontal plane by spring-loaded rollers. The mass is lifted by cables, drive chains, long-stroke hydraulic actuators, or gas actuators. The cycle rate is very low, perhaps as low as 2 drops per min. Only one blow is applied before the machine moves to its next drop location. The blow energy is

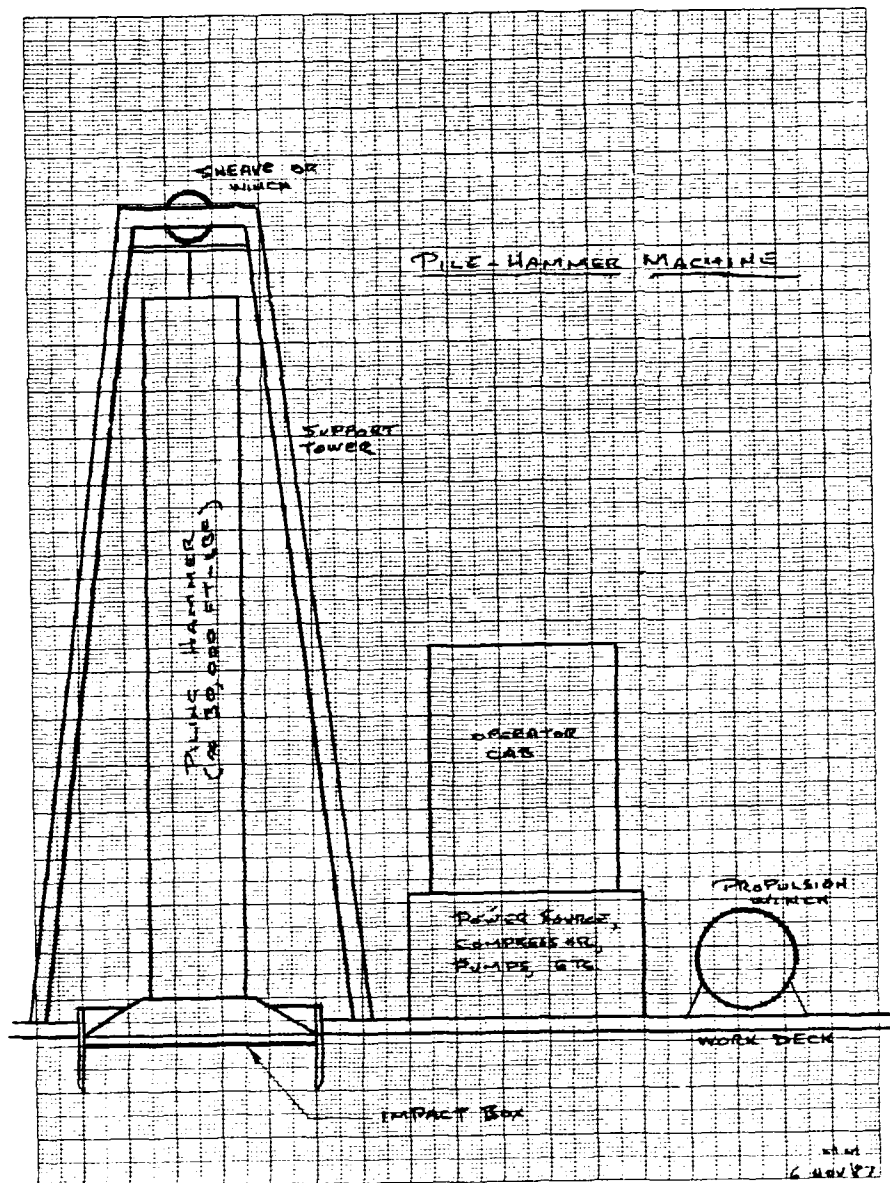

Figure B-2.

approximately 320,000-480,000 ft-lbf (0.43-0.65 MJ), which is equivalent to the blow energy of a large piledriver, either diesel or air/steam. To raise the drop weight in 15 seconds, the minimum power requirement is about 40-60 hp (29-43 kW).

In the version of the machine that uses a low frequency hammer, the impact box is set in contact with the snow and it is then beaten in. The top of the box carries a frame that is designed to carry the impacts and stress pulses without permanent deformation, fracture or fatigue failure. At each location, the snow is subjected to something on the order of 10-15 impacts, each of the order of

30,000 ft-lbf (40 kJ) for the box dimensions that are used in these examples. This is equivalent to the blow energy of a fairly small piling hammer. In a diesel system, the hammer weight might be about 1.5 to 2.5 tons, with a frequency of about 40 to 80 blows/min. For an air/steam system, the traveling mass might be twice as big as this.

The machine is likely to be mounted on skis, or sled runners, which adjust so that the impact tower can be kept vertical when operating on an inclined or stepped snow surface. In the basic form of the machine, straight-line travel from one impact location to the next can be provided by a winch-and-

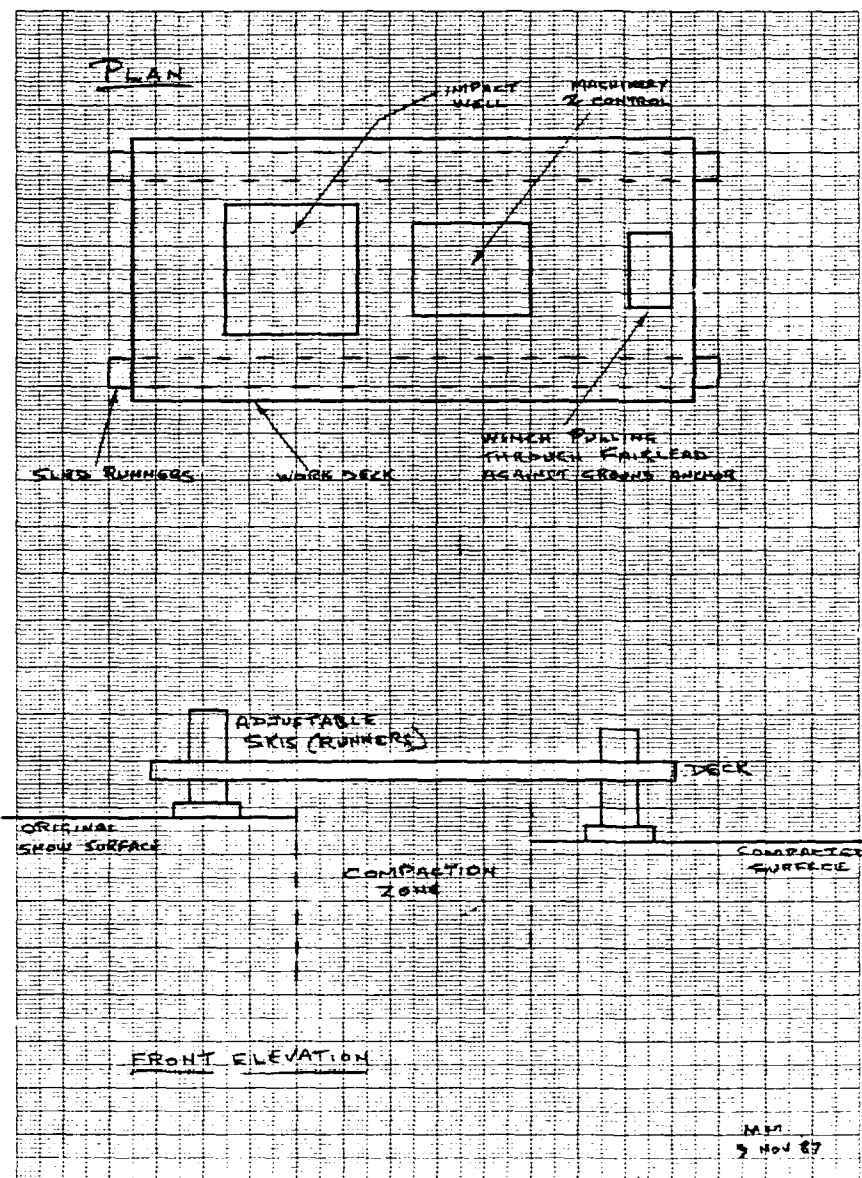

Figure B-3.

cable system. The machine could also be mounted on self-propelled tracks.

Operating procedure

Since a snow runway must have no soft spots, the depth-compaction process has to be applied uniformly over the entire area of the runway. This can be done by traveling with the machine along lanes, moving forward one plate width at a time. With the numbers used in the earlier examples, each compaction lane would be 5 ft (1.5 m) wide and the machine, or its impact tower, would move forward in increments of 5 ft (1.5 m).

If the impact tower can move to a new position and deliver the required number of impacts in 30 seconds, forward progress is 10 ft/min and the area is compacted at 50 ft²/min. With unbroken production, one machine could cover a total area of 2×10^6 ft² in under 700 hours, or in about 33 days with 20 hours of continuous working per day.

Operating principles

The type of compactor that is described here has behavior somewhere between that of a quasi-station foundation and a fast projectile.

The static foundation sets up an elastic (Boussinesq) stress distribution, and all snow within a certain stress contour compacts because its resistance is lower than the applied stress. The compacted snow then becomes temporarily rigid, thus changing the effective geometry of the foundation (or indenter). Additional load or displacement produces more compaction of the disturbed snow, together with downward propagation of the interface between disturbed and undisturbed snow.

By contrast, a flat plate impacting the snow surface at very high speed produces impact stress and a stress wave in the snow. The elastic wave travels into the snow at about 1 km/s or more. Snow particles pile up against the traveling plate in a type of shock phenomenon, and a thin layer of high density can be formed before the plastic wave front propagates into snow that is still undisturbed by anything other than the non-de-

structive elastic wave. With impact at very high speed (~ 1 km/s) there is a true shock in the snow and dense ice can be formed at the impact surface.

To treat these problems analytically we require a type of constitutive relation called the Rankine-Hugoniot characteristic or, more briefly, the Hugoniot. This type of relation has not been determined satisfactorily for snow.

Using the drop-weight impactor or the hammer impactor, we expect the initial resistance to be small, since the surface snow has low density (high porosity) and its compaction resistance is far below the impact stress. As the surface layer crushes, it transmits the high stress to lower layers, which then collapse progressively. Since there is a finite resistance to penetration of the impactor, it decelerates and loses energy and it will eventually come to rest. Some of the energy, probably a minor proportion, will be lost in the elastic wave that propagates into the snow.

The depth to which the plate penetrates is dependent on the width of the plate and the energy per unit area. The disturbance ahead of the plate, either elastic or plastic, has linear dimensions that are proportional to the plate width (to a first approximation, assuming the snow is more or less homogeneous). The plate will continue to penetrate until all of its energy has been dissipated in some way. In the unlikely event that too much energy is supplied, the plate will develop a zone of dense snow that is effectively rigid (the "false nose" of plasticity theory), turning itself into a pointed or rounded indenter that displaces snow sideways instead of compacting it vertically.

For the machines described here, we do not expect initial impact velocity to exceed about 10 m/s. For a 1.5 m square plate with skirts, we expect compaction effects to be measurable to depths of the order of 1 m below the plate. There is likely to be a density gradient, with the highest density directly below the plate.

Experimental data would be useful for refining the design. Weights dropped by a crane would provide analogue tests. Hugoniot data and plate penetration data would be useful for systematic analysis.

Relative merits of design options

There is not likely to be much difference between the two design options in terms of total weight and overall height. The relatively small piling hammer could have a stroke of almost 10 ft, a total weight of over 4 ton, and an overall height of about 15 ft. Both systems are simple mechanically, and neither requires much fuel.

Without field tests, relative effectiveness for compaction cannot be judged. The drop weight may achieve more compaction for a given input of energy. However, the piling hammer probably gives better "fine tuning"; it can run until the plate has been driven to the required depth, as indicated by a laser guide beam.

APPENDIX C

Base Course Processor for Snow Roads and Runways

Introduction

Typical surface snow on the ice sheets of Antarctica and Greenland is too weak to support standard wheeled vehicles and aircraft. This is largely because the bulk density of the snow is too low (i.e. the porosity is too high). In order to carry repeated traffic without deteriorating, snow roads or snow runways require: (1) a pavement surface that resists indentation and rutting at the applicable tire pressures, and (2) a pavement/base-course combination that forms a slab capable of supporting the total load.

An efficient way to prepare a strong base course is to mix or mill the natural snow mechanically, re-depositing it with higher density (lower porosity). The goal is to achieve a density (porosity) that approaches the value for closest packing of uniform, equidimensional grains. This is a density of about 0.55 Mg/m^3 , or a porosity of about 40%. After redeposition, intergranular bonds develop with time, giving consequent increase of strength with time. This sintering process, which depends largely on vapor diffusion and surface diffusion of water molecules, is a thermally activated process, with its rates strongly dependent on temperature. Sintering is also dependent on a high proportion of very small ice particles, which tend to evaporate (and redeposit) even at low temperatures. In the past, conventional rotary snowplows and agricultural rotary tillers have been used to mill, mix and redeposit dry snow.

When a conventional rotary snow plow is used to process snow, its rate of advance relative to the rotor speed is such that relatively large fragments are cut near the original snow surface, where each rotor blade takes its maximum bite. Fine fragments are cut at the bottom of the working layer, where blades enter or leave the snow with zero bite. A mixture of fine particles and larger fragments is gathered into one or more ejection chutes, often by auger action and sometimes by a secondary impeller. A stream of material is then projected through the air. This

results in a winnowing action, especially in windy weather, and grain-size segregation produces a non-uniform snow deposit, in which some sections are deficient in the fine particles which stimulate sintering. The spray of snow equilibrates to the ambient air temperature; at very cold sites, this can inhibit initial intergranular cohesion.

The machine described here is designed specifically for processing the base course in a snow road or snow runway. It is expected to be significantly more efficient than existing machines, to achieve much better quality control, and to permit construction at sites that are too cold for useful application of existing equipment. These things are achieved by: (1) appropriate control of rotor speed, blade settings, and forward speed, (2) conveyance and redeposition of cuttings inside a closed volute chamber, (3) transfer of heat, including most of the dissipated energy, to the redeposited snow. The net effect on the processed snow is: (1) high density (from deposition, screeding and planing), (2) bond development by sintering (high proportion of very fine surface-active powder from multi-blade high-speed rotor), (3) well-homogenized, uniform deposit (from turbulent mixing in the volute chamber), (4) stabilized surface (from use of insulated shroud, heating, and "energy sink" principle).

General description of the machine

The machine is intended to process natural snow to a depth of about 0.75 m, producing a base course about 0.5 m thick. While comminuting and homogenizing the snow the machine retains "rejected" heat, finally screeding and smoothing the deposit and glazing its surface.

The leading element of the machine is an upmilling rotor which revolves about a horizontal axis that is normal to the direction of travel. The rotor is a closed drum fitted with projecting blades that lie along generators of the cylindrical drum. These blades act both as cutters and as impeller vanes for the cuttings. The rotor ejects snow particles tan-

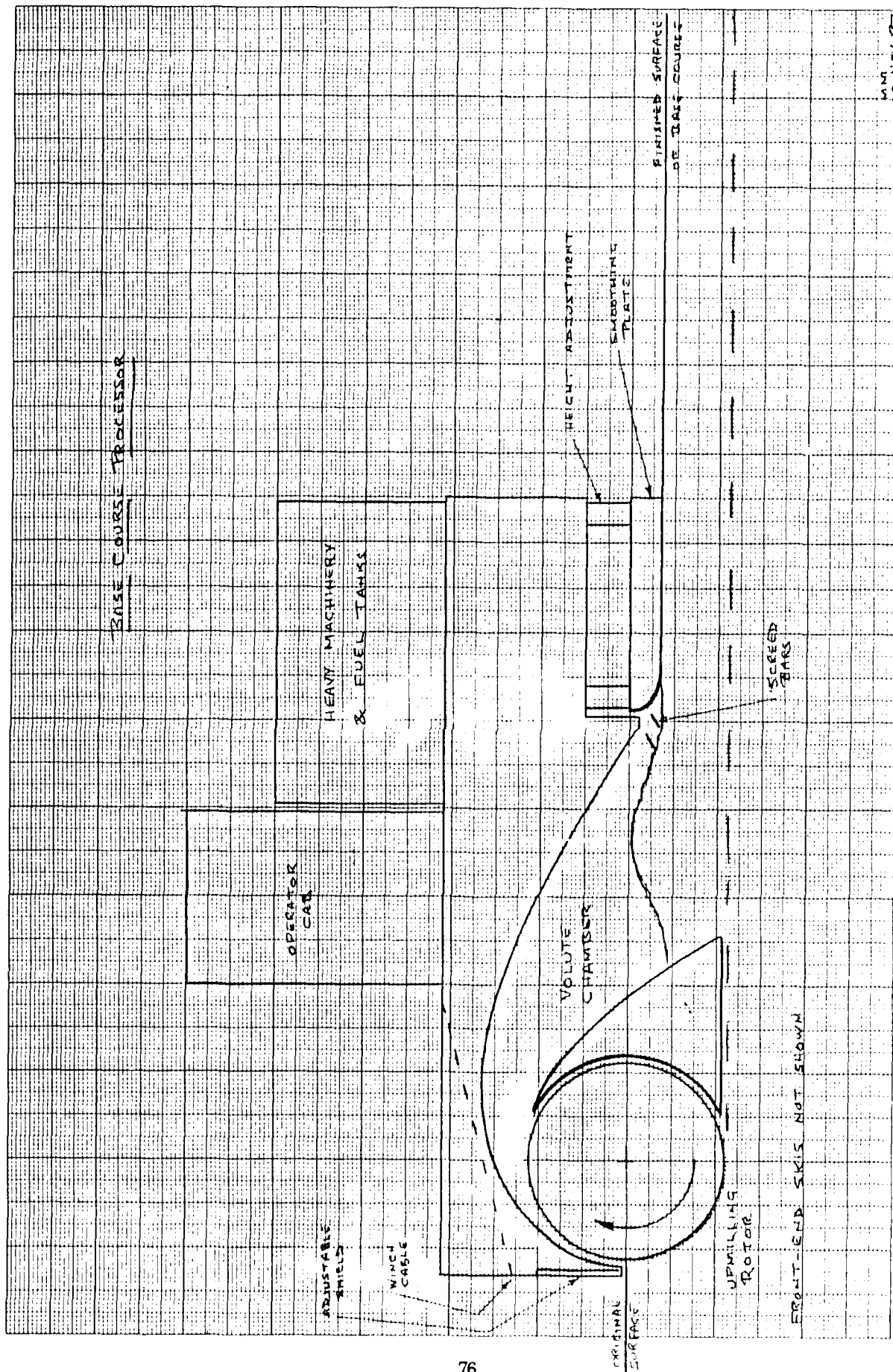

Figure C-1.

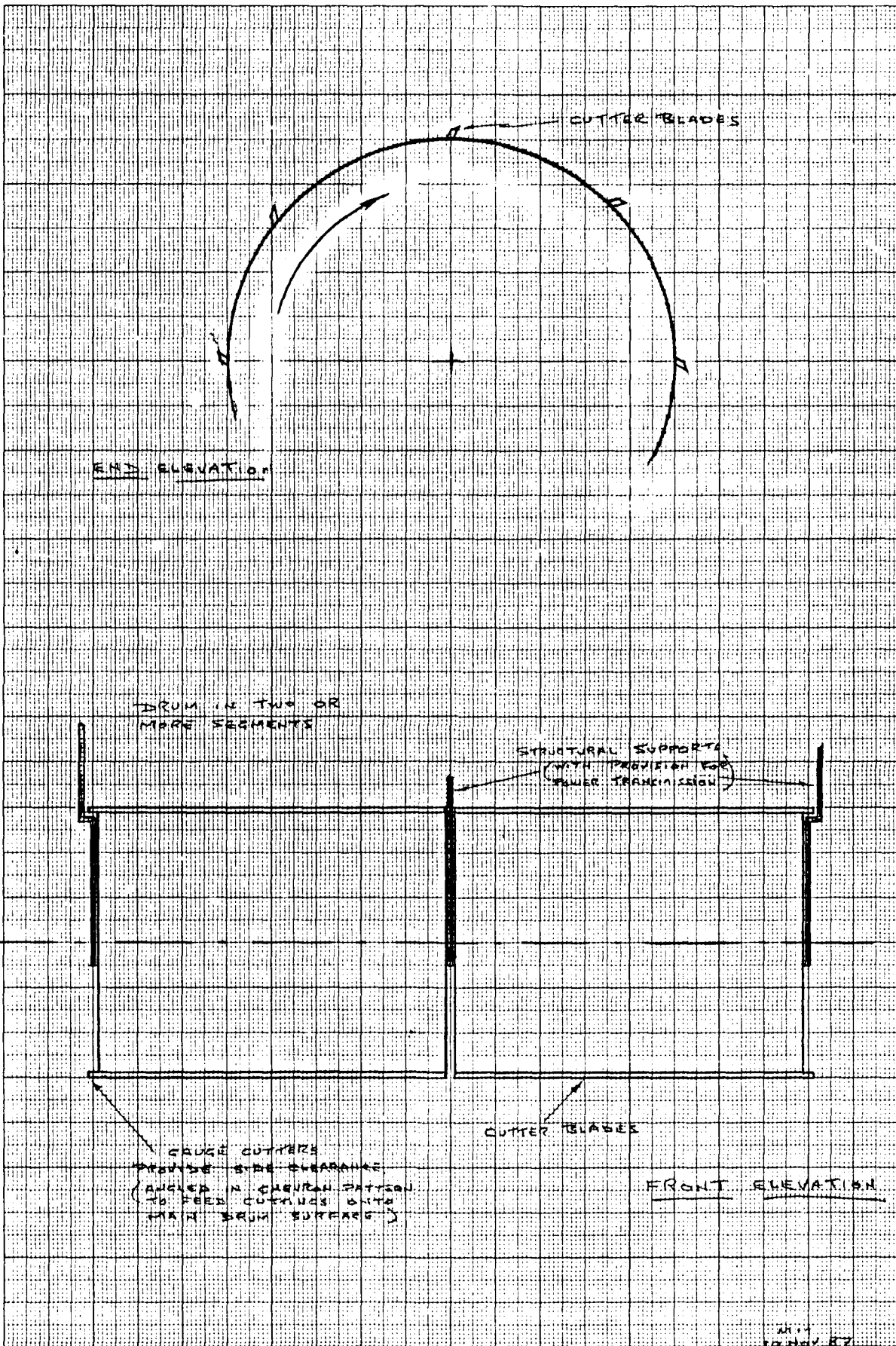

Figure C-2.

gentially into a volute chamber, much like a rotary pump. Turbulent mixing in the volute chamber stirs together particles of different sizes cut from different levels of the original snow pack.

Behind the volute chamber there are adjustable screed bars that spread the deposited snow uniformly.

At the rear of the machine is a plate that smoothes, compacts and glazes the surface of the base course. This plate extends across the full width of the machine, and its leading edge is curved up like the front of a toboggan. Its front-to-back dimension is kept small, so as to maximize the bearing pressure while avoiding indentation and shearing. The surface of the plate has an ice-phobic coating and its temperature is adjustable within certain limits by means of a heat exchanger which recovers energy from the rotor engine.

All working elements are shrouded to provide convection barriers and thermal insulation.

The power plant, fuel tanks, heater, and operating controls are carried on a platform above the working elements. The machine is supported on skis at the front end, and by the smoothing plate at the rear end. Most of the weight is concentrated above the smoothing plate so as to maximize the compaction force. The front-end skis support the milling drum and its frame, and also resist vertical drum reactions that are produced by the upmilling action. These skis also adjust so as to control the processing depth. Large fuel tanks at the aft end are used to ballast the smoothing plate.

In its basic form, the machine is propelled horizontally in a straight line by a winch-and-cable system. A self-propelled variant can be made by substituting tracks for the smoothing plate, maintaining the strategy of using most of the machine's weight for compaction.

Design of the rotor

The outside diameter of the rotor and blades is about 4 to 5 ft (1.2 to 1.5 m). The rotor width is to some extent arbitrary, but a width of approximately 12 ft (3.7 m) is probably convenient. The rotor is built in sections, each 4 to 6 ft (1.2 to 1.8 m) wide, in order to provide adequate bearings, structural sup-

port, and power transmission. There is a narrow gap between adjacent sections.

The rotor drum is fitted with approximately six to eight cutting blades, or vanes, each set along a generator of the drum's cylindrical surface. The vanes project only a small radial distance from the drum surface (≈ 1 in., or ≈ 25 mm) so as to prevent the rotor from pumping too much air into the volute chamber. These vanes, or blades, are angled and ground so as to provide positive rake and relief angles at the cutting edge.

The drum rotates fast and travels forward slowly, so as to mill the snow to very fine grain size. As each blade enters the cut at the deepest point, its "chipping depth," or radial penetration, is zero. The chipping depth increases through the working sweep, reaching a maximum at the exit from the work (provided the processing depth does not exceed the drum radius). If the radial chipping depth is l , the maximum chipping depth l_{\max} is given by

$$l_{\max} = \frac{2U}{fn} \cdot \frac{h}{D} \left(\frac{D}{h} - 1 \right)^{1/2}$$

where U is the forward (horizontal) speed, h is the processing depth (from the original surface), D is the overall rotor diameter, f is the rotation speed (frequency), and n is the number of blades on the drum. Taking practical values of $U = 10$ ft/min, $D = 4.5$ ft, $n = 8$, $f = 250$ rev/min and $h/D \geq 1/2$, the value of l_{\max} is 0.06 in., or 1.5 mm. This is considerably smaller than typical values of l_{\max} for rotary snow plows.

The in situ volume of snow milled by each blade during one working sweep is (Uh/fn) per unit drum width. For the drum parameters used in the example above, each blade cuts away 1.6 in.² (10³ mm²) from the processed section when $h/D = 1/2$, and thus there is ample space available for conveying the fragments into the volute chamber.

The cuttings leave the rotor at high speed. The tangential velocity at the blade tips, u_t , is (neglecting the small effect of U):

$$u_t = \pi Df.$$

With the values given above, u_t is 3534 ft/min, 40 mile/hr, or 18 m/s.

The cutting edge of each blade has an included angle of 30° to 45°. It is set with a relief angle (measured from the tangential direction) of approximately 12°, giving a positive rake angle (measured from the radial direction) of about 33° to 48°.

When the rotor is running axle-deep, it processes the original snow at a volumetric rate of $UBD/2$, where B is the rotor width. Taking $B = 12$ ft, $D = 4.5$ ft and $U = 10$ ft/min, the original snow is processed at 270 ft³/min, or 10 yd³/min. For snow of original density 0.37 Mg/m³, this is 3.1 ton/min.

The minimum power required for accelerating the mass of cuttings, P_A , is (neglecting the small effect of U):

$$P_A = (\rho/2)(UBD/2) u_t^2$$

where ρ is the original snow density. Using the numerical values from the earlier examples, P_A is only about 10 hp.

The minimum power needed for cutting the snow can be estimated by guessing values for the strength of the snow and the energetic efficiency of the process (Mellor, 1977). Surface snow with density less than 0.4 Mg/m³ is not likely to have a uniaxial compressive strength much above 15 lbf/in.², or 0.1 MPa. Taking the ratio of specific energy to strength as being of order unity (moderately conservative), then the required cutting power is only about 18 hp for the design dimensions used earlier. If the machine is required to work at the same rate in snow of high density (approaching 0.5 Mg/m³), the required cutting power could increase by an order of magnitude because the strength of the snow is much higher.

Power is also needed to overcome friction in the bearings and transmission, rotor windage, and other losses.

Practical experience provides guidance on the rotor power requirements. For a rotor of the size considered above, a heavy-duty rotary snow plow might have about 350 hp installed. This would probably power the rotor, drive the wheels or tracks, and perhaps drive a secondary impeller. The plow would have a greater output, in terms of mass or volume per unit time, since it would rarely travel as

slowly as 10 ft/min. The plow would also cast the snow to considerable height and distance.

Taking into account the estimated minimum power requirements for cutting and accelerating the snow, and looking at the installed power of comparable snow plows, it seems that about 250 hp might be suitable for a machine that has to work in a variety of site conditions.

Design of the smoothing plate

The smoothing plate extends across the full width of the processing lane (12 ft, or 3.7 m, in the example used here). It has a flat base, approximately 4 ft (1.2 m) from front to back. At the leading edge there is a transition curve to provide smooth and gradual compaction of loose surface snow.

The smoothing plate carries most of the weight of the machine, including the power plant, transmission, pumps, controls, operator cab, and fuel tanks. If necessary, extra fuel can be carried as ballast. Even with extra fuel, the loading on the bearing surface of the plate is not likely to be much above 1,000 lb per ft of width, which is less than 2 lbf/in.² (= 12 kPa). This is far too low for effective compaction of snow that is already approaching a density of 0.55 Mg/m³.

The smoothing plate is preceded by two (or more) screed bars which distribute the snow to give a level surface. The first bar takes the tops off the hump of snow deposited behind the miller. The next bar is set lower to continue the process. The lowest bar of the set has its scraping edge about 0.5 in. (= 1 cm) above the base level of the smoothing plate.

Heat exchange coils are built into the smoothing plate. These are intended to recover heat from the exhaust and coolant of the power plant, and possibly from auxiliary systems. The top of the smoothing plate and its vertical edges are insulated. The base of the plate is a good thermal conductor, such as aluminum, with a thin outside surfacing of polyethylene or other ice-phobic material (like a ski base).

The smoothing plate adjusts vertically relative to the milling drum and its supporting skis.

Heating systems

In considering snow compaction at very cold sites, such as the South Pole, many people have concluded that artificial addition of heat, or liquid water, will be needed to produce strong snow. However, we find the calculated heat requirements to be discouraging, especially when the true cost of fuel at the South Pole is considered.

The energy consumed and dissipated by the rotor-drive system is insufficient to produce a significant temperature rise over the full depth of the processed layer. For example, if the entire 250 hp is converted to heat flow into snow which is being processed at 3.1 ton/min, the temperature rise is less than 2°C. Probably the best use for heat reclaimed from the exhaust and cooling system of the rotor engine is heating of the smoothing plate so as to glaze the top of the processed layer. This can be arranged by building a heat exchanger into the smoothing plate. If 50% of the total power is transferred as heat to the snow surface by a very warm plate, approximately 1 mm of meltwater could be produced with the machine traveling at 10 ft/min (assuming small conduction loss to the underlying snow).

Heating the entire processed layer requires a large amount of energy. Adding water, even a very small proportion, requires even more energy. If the machine is processing cold snow at a rate of 3.1 ton/min,

and if the temperature of the processed snow has to be raised by 15°C, then a minimum of 2.1×10^7 cal/min of energy must be transferred. This is equivalent to 4.3 lb/min if DFA is burned with 100% thermal efficiency, or 0.6 gal./min. For an airstrip covering 2×10^6 ft², this is 10,000 gal. at a working speed of 10 ft/in and 100% thermal efficiency.

The highest thermal efficiency can be achieved by direct application of flame, using the volute chamber as a combustion chamber. However, there is then a need to remove exhaust gas at high flow rates, and to separate snow particles from the exhaust gas. It is probably better to have a separate combustion chamber running the exhaust through heat exchangers inside the volute chamber. To maximize the temperature difference on the heat exchanger, the hottest end would be nearest the exit of the volute chamber, and the coolest end would be in the ejection stream of the rotor.

Other schemes for injecting heat or steam have been considered. These include injection of steam into a coherent snow layer, using well-distributed nozzles to avoid the undesirable channeling and piping that occurs when water is applied to a snow surface. At this stage, it seems preferable to concentrate on mechanical processes, milling the ice fragments as fine as possible with a rotor and relying on molecular diffusion under natural potential gradients to form bonds between the larger ice grains.

APPENDIX D

High Pressure Compaction Machine

Introduction

Compaction of snow or soil is usually a low-pressure process, with the vertical pressure typically less than 50 kPa (7 lbf/in.²). There are two reasons for this low pressure level: (1) weight limitations for vehicles and rollers, (2) penetration by punching when pressure is too high. Higher pressure levels can be reached by inertial devices (e.g. vibrators) but the strain rates induced by brief transient stress are very high and, with limited bearing area, punching is still a possibility (e.g. with high energy impactors). In deep snow or deep soil there is no hard substrate to provide reaction, and punching is inevitable if the bearing pressure is higher than the typical range for existing compactors.

One shortcoming of low-pressure compaction is that the compacting pressure may be lower than the bearing pressure of the wheels or tracks of the expected traffic, so that the compacted material has to be covered by a paved surface, or it has to develop internal cohesion after compaction (e.g. sintering in snow, chemical cementing in soils).

The machine proposed here has the capability of compacting snow or cohesive soil to pressures at least an order of magnitude higher than those used in standard compaction work. The initial design is expected to give pressures up to 2 MPa (300 lbf/in.²).

Description of the machine

In essence, the machine slides a horizontal plate beneath the surface of the snow or cohesive soil and presses another horizontal plate down onto the surface of the snow or soil. The vertical sides of the compressed slab are confined by vertical plates. The machine then moves forward, leaving behind one or more compressed "paving slabs".

The working elements are carried on a portal frame structure that has its adjustable legs set on skis, tracks, or wheels (Fig D-1 and D-2). The horizontal reaction plate hangs from the portal frames by two or more

vertical plates (Fig D-1 and D-3). The width of the reaction plate, or the width of each bay, is limited in order to limit the deflection and stress of the plate under load. The leading edge of the reaction plate, and the leading edges of the vertical hanger plates, are sharp so as to facilitate horizontal penetration. The surface of the reaction plate and the hanger plates are polished and/or coated so as to minimize friction. The movable upper plates (compression plates) hang from hydraulic actuators or mechanical jacks, which themselves hang from a traveling frame. Each compression plate has vertical end plates fore and aft. The lower edges of these vertical end plates are sharp. Surfaces of the compression plate are polished and/or coated to reduce friction. The compression plates travel fore and aft on a gantry.

The power plant, the hydraulic pump and reservoir, and other mechanical items are carried on a deck above the portal frames. The gantry for traversing the compression plates fore and aft is suspended below the portal frames.

In its basic form, the machine travels forward in a straight line by pulling itself against an anchor, using an on-board winch. It can also be self-propelled by tracks or wheels.

Mode of operation for slab-making

The machine will normally work on a surface that has been graded to some extent. To begin operation, the machine is moved over a shallow pit that is slightly bigger in plan than the reaction plate. The legs of the portal frame are adjusted vertically so as to set the reaction plate at the required depth.

The first step is to advance the pressure plate over the undisturbed working surface and lower it until the flat surface of the plate is just bearing on the surface. At this stage, the edges of the fore and aft vertical cutoff walls are slightly above the level of the top surface of the reaction plate (Fig D-5). The machine then moves forward while the pressure plate remains stationary relative to the ground (i.e. it moves backward relative to

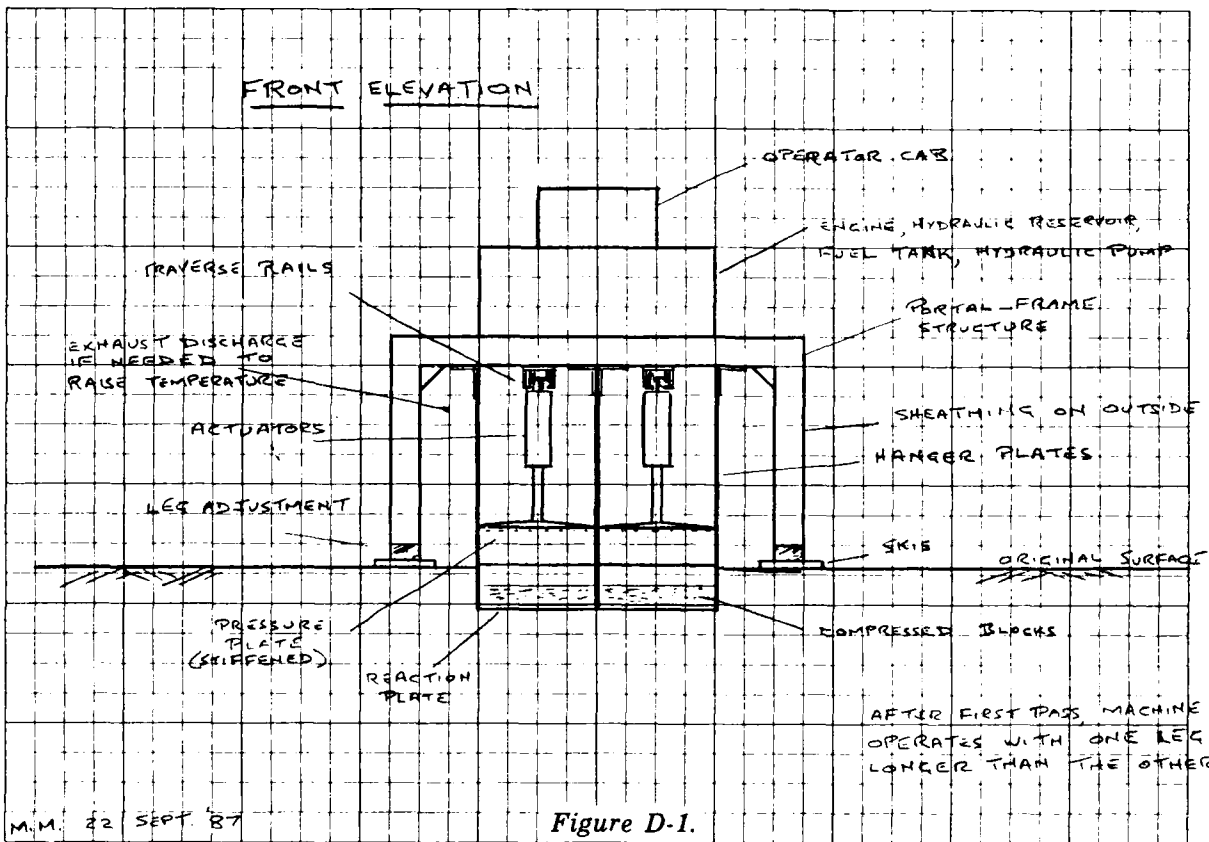

Figure D-1.

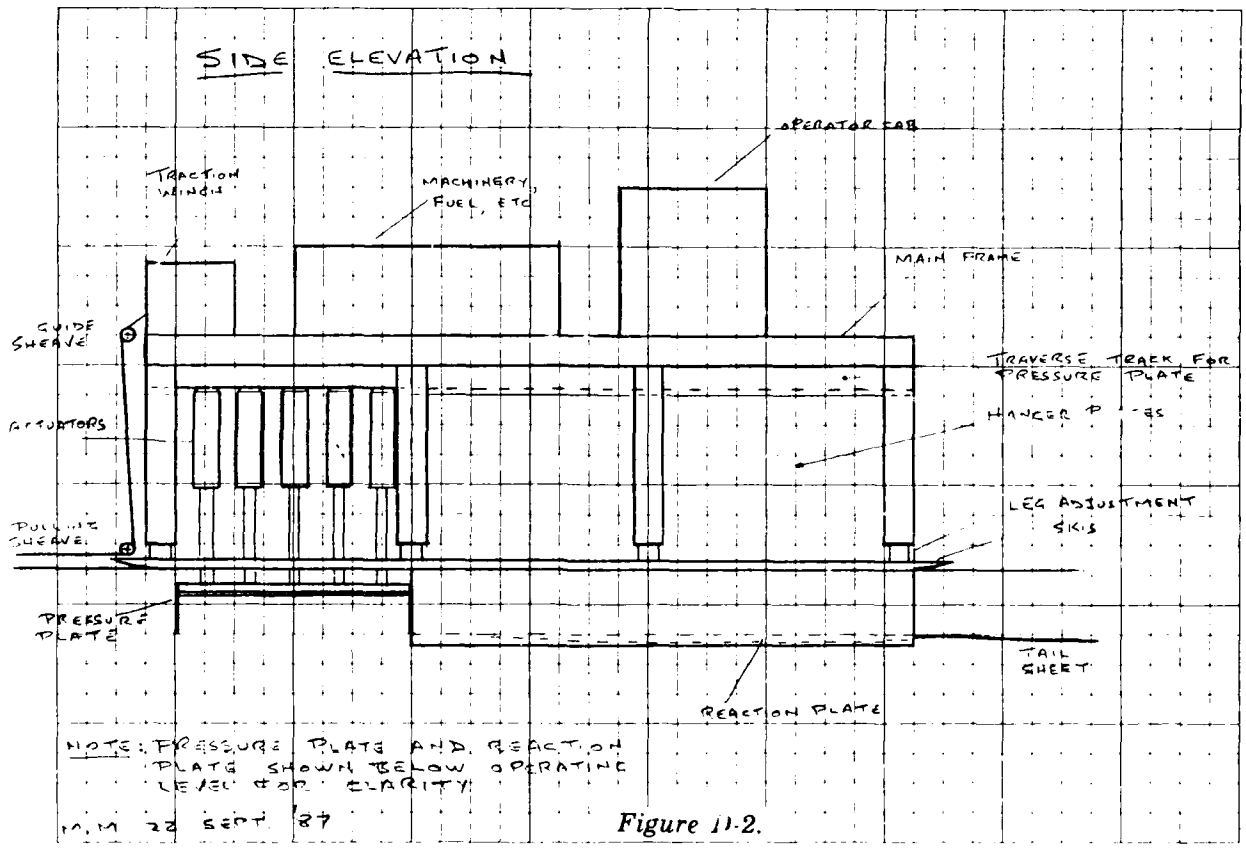

Figure 11-2.

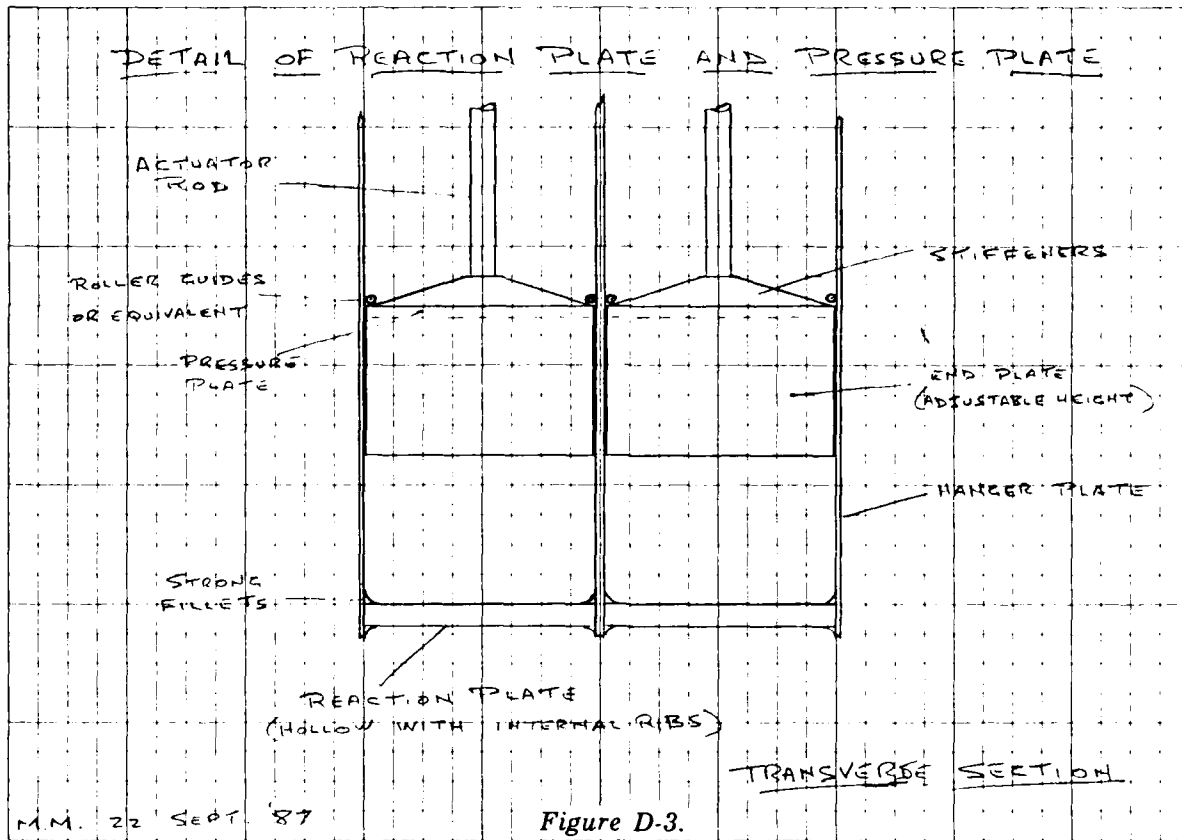

Figure D-3.

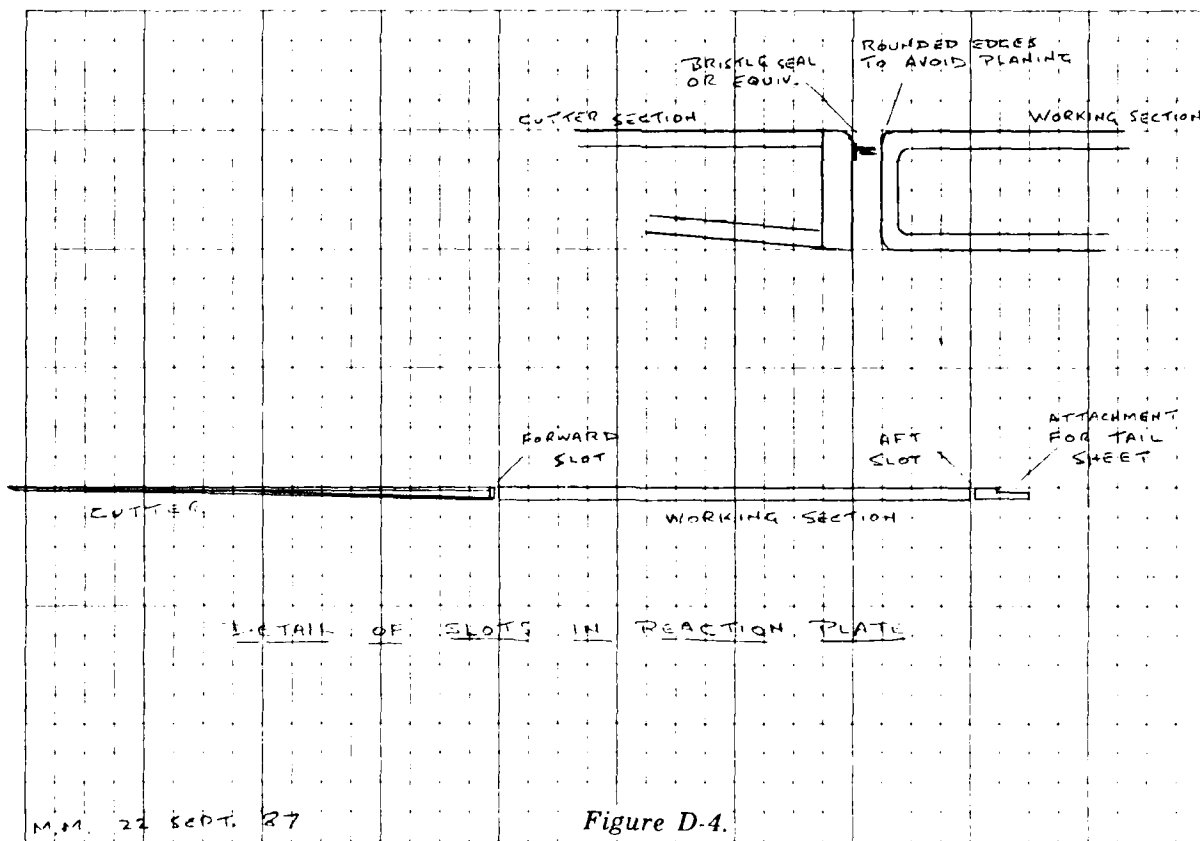
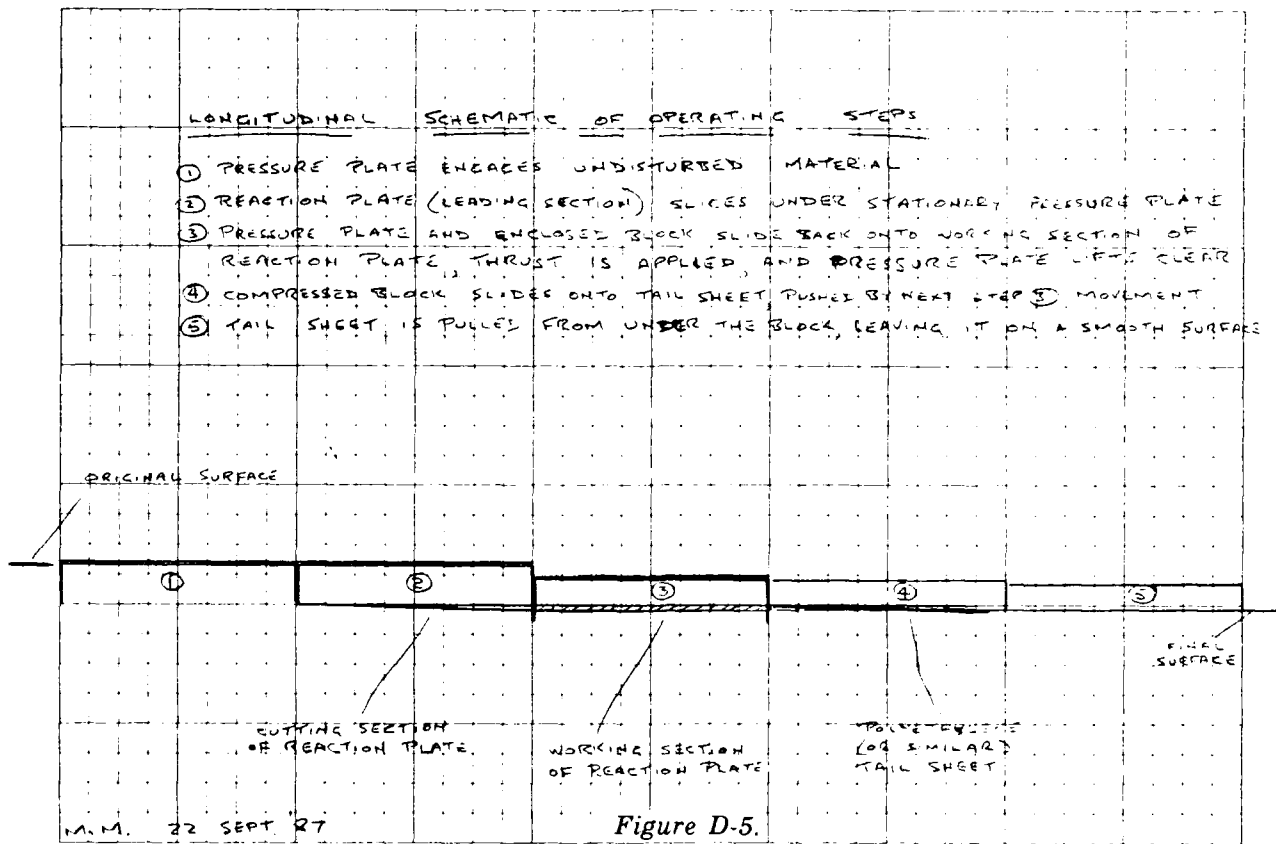

Figure D-4.



the machine frame at the same speed as the frame moves forward relative to the ground). This motion causes the cutter section of the reaction plate, and its hangers, to slice into the snow or cohesive soil; it effectively moves a box of material onto the cutter section of the reaction plate (Fig D-5). The pressure plate then moves aft relative to the machine, transferring itself and the block of material onto the working section of the reaction plate.

With the compression plate and the material positioned accurately on the working section of the reaction plate, vertical thrust is applied and the enclosed snow or cohesive soil is compacted (Fig D-5). The fore-and-aft end walls of the compression plate run down into transverse slots, which have seals to prevent abrasion and spillage when the work block is traversing the reaction plate (Fig D-4). The compaction process takes place inside a fully enclosed box, and approximates to compaction in a state of uniaxial strain.

The limit of the vertical stroke can be set by limiting the pressure or load on the actuators (stress control), or by limiting the vertical travel (strain control).

At the end of the thrust operation, the compression plate is retracted and traversed forward to a new starting position for a repeat of the entire cycle. The compressed block is left on the reaction plate. As the next block is moved onto the reaction plate, it slides back one block length onto a thick polyethylene sheet that is attached to the tail of the reaction plate. In this position, it may be necessary to engage an ejector to hold it stationary relative to the ground, so that the polyethylene sheet slides from under it as the machine advances. The block is then left on a smooth surface planed by the underside of the reaction plate working section.

For second-stage compaction over a base of previously-processed slabs, the machine can be modified by removing the reaction plate and compacting against the existing pavement. In this case, the actuators are fitted with smaller pressure plates which operate sequentially. The size of each pressure plate is determined by the limit of static reaction provided by the weight of the machine. Each pressure plate is in the form of an open box, with four vertical sidewalls whose height is

adjusted to suit the thickness of the compaction layer. The walls of the box can be made to slide vertically relative to the pressure plate itself, with a spring-return operating on retraction.

Design estimates for a prototype snow compactor

The size of a prototype snow compactor is chosen such that the machine would be practical for construction of a snow runway. The area to be compacted in one cycle is 32 ft². With a one-minute cycle time, 10⁶ ft² could be compacted in 521 hours, or 26 days with 20 hours of actual production. In principle, the base course for a runway with 2x10⁶ ft² (200 ft. x 10,000 ft) could be processed in one month by two machines.

The aim is to achieve compaction to a pressure of 300 lbf/in.². For an area of 32 ft², this is a total force of 691 tons. If we assume hydraulic actuators with a working pressure of 3000 lbf/in.², the ratio for piston area to compaction area is 1/10, or 3.2 ft² of total piston area. Using 6 in. diameter actuators, 16 would be required.

If the snow is compressed to 300 lbf/in.² at high rate (20 to 30 s), it is expected that the resulting final density would be in the range 0.65 to 0.70 Mg/m³, depending on the processing temperature and the duration of pressure. Strain rates are likely to exceed 10⁻² s⁻¹, but the process is much slower than the compaction induced by conventional compactors. With slab density in the range 0.65 to 0.70 Mg/m³ the slab should support 30 lbf/in.² indefinitely, without any significant indentation by collapse or creep.

The vertical travel of the compression plate might be about 40 to 45% of the initial thickness of the processed layer (it will vary with initial snow density). Assuming 15 in. as the initial thickness of the processed layer, with initial and final densities of 0.38 and 0.68 Mg/m³ respectively, the pressure plate would travel about 6.6 in. and the finished slab would be 8.4 in. thick. The total energy consumed by snow compaction over an area of 32 ft² would be about 3.8 x 10⁵ ft-lbf. To supply this energy in a period of 20 s, the required power would be 35 hp. This is the output of the hydraulic actuators.

It is desirable to have each slab as big as possible, but there are practical limits. The length of the slab (in the machine's direction

of travel) is limited by accumulation of friction when the reaction plate slides beneath it. It is estimated that 8 ft would be reasonable. If this is too much, or if greater lengths are needed, the pressure plate can be fitted with intermediate vertical cutoff plates.

The width of the slab is severely limited by the flexural rigidity of the reaction plate. For example, if the reaction plate is 1 in. steel, and if it is attached to the hanger plates by welding in strong quarter-round fillets, the maximum permissible separation between hangers is about 15.5 in. If more conservative assumptions are made and each bay of the reaction plate is regarded as a simply-supported slab, the permissible width is only 9 in.

To provide a strong working section for the reaction plate, it could be made as a 2-in.-thick box with internal ribs. Boxes could perhaps be made about 2 ft by 8 ft, with transverse welded ribs inside. Alternatively, a box plate could be made by welding together rectangular steel tube sections, e.g. 6 x 2 x 1/4 in. steel tube.

Looking at the reaction plate in longitudinal (fore-and-aft) cross-section, the leading 8 ft would be fabricated from thin (1/4 in.) steel plate to provide a clean undercut beneath the uncompacted slab (Fig D-4). The next 8 ft section, the working section, would be a strong box section. Trailing from this would be a thick polyethylene sheet (Fig D-4).

The hanger plates (Fig D-3) are less of a problem. Using 1/4-in. plate, the tensile stress is well below the allowable working stress of the steel. However, the welded connections between the hanger plates and the reaction plate must be robust. The hanger plates might have to project below the reaction plates to allow for a good connection (Fig D-3).

The thickened working section of the reaction plate will compact and smooth the underlying snow. This is desirable to provide a bed for the ejected slab. The machine has ample weight to provide the necessary vertical force over an area of 32 ft².

If this machine is used for second-stage compaction without a reaction plate, each pressure plate could be no bigger than 2 ft by 2 ft. With a compaction pressure of 300 lbf/in.², the reaction required by each plate in a sequential operation would amount to 86 tons. Thus the machine would have to be ballasted.

**APPENDIX E: COMMENTS ON THE REPORT
COMPACTED SNOW RUNWAYS BY D.S. RUSSELL-HEAD AND W.F. BUDD**

The Australian report indicates that prospects for a hard-surface snow runway at Casey are very good, and the authors seem optimistic about snow compaction at McMurdo and South Pole.

The runway site at Casey is probably a very favorable location for snow compaction by simple methods. The site is just north of the Antarctic Circle at an elevation of about 500 m (1,600 ft). The net accumulation is quite small, about 10 cm of water per year. The natural snow has very high density, averaging 0.48 Mg/m^3 for the topmost annual layer, so that the net thickness of a one-year accumulation is 21 cm, or just over 8 in. The daily mean temperature averages about -3°C in December and about -1°C in January, making the snow moist and cohesive in those months. After rolling, densities of 0.7 Mg/m^3 were achieved; this should provide ample support for aircraft wheels as long as the intergranular cohesion of the compacted snow is not destroyed by melting or excessive grain growth.

A scenario for the annual maintenance cycle was not considered in the Australian report. The runway would presumably be constructed in summer, probably as an elevated runway. By late summer it would be very hard and suitable for air operations. Through the following winter and spring, the runway could be kept in operation by plowing new snow off to the sides. Alternatively, attempts could be made to compact new snow progressively, taking advantage of any warm spells that might be experienced. However, this compaction might be inefficient until about November. During the summer, the compacted snow would be exposed to high air temperatures and strong solar radiation. It might have to be protected by blowing fresh snow over the surface, and this could be the basis for the annual compaction operation that maintains the elevation above the

surrounding snowfield. It should be noted that compaction of the annual increment of natural snow accumulation is not sufficient to maintain the runway elevation; the thickness of the compacted layer must equal the thickness of the annual layer of uncompacted snow adjacent to the runway. This means a layer with about 46% more mass than the natural layer.

The techniques developed in the Australian study ought to be applicable on the Ross Ice Shelf near McMurdo, especially at sites further west than the Williams Field skiway (i.e. sites with a small annual increment of snow accumulation). However, there is no certainty that a compacted snow runway in this location can remain hard throughout the summer unless it receives frequent dustings of fresh snow. It has been reported that the Soviet snow runways are closed to heavy wheeled aircraft in summer because of surface softening. There is also a question of whether milling and rolling is justified in this location, as a solid ice surface is available by moving slightly further west.

At the South Pole, conditions are very different from those at Casey. Natural clean snow is never moist and cohesive, and neither is snow milled by an ordinary rotary snow plow. It seems likely that a heavy roller would break the intergranular bonds of the snow and stir it up like dry beach sand. This could produce a snow density around 0.5 Mg/m^3 , but probably not much more unless the snow is treated with some kind of melting agent.

To sum up, compaction by a variable-ballast heavy roller has strong practical appeal, but it is not yet certain that the method can provide an all-season wheel runway. More information on Soviet experience with snow runways would be very useful.